



Inogun M / Inogun M +

Powder Spray Gun

Instruction manual

DRT7132

D - 2022/09

All communication or reproduction of this document, in any form whatsoever and all use or communication of its contents are forbidden without express written authorisation from **Sames**.

The descriptions and characteristics mentioned in this document are subject to change without prior notice

© Sames 2020 - translation of the original version

Sames operating manuals are written in French and translated into English, German, Spanish, Italian and Portuguese. The French version is deemed the official text and **Sames** will not be liable for the translations into other languages.

Services



Certification and referencing

Sames is certified as a training center by the DIRRECTE of the Auvergne Rhône Alpes region under the number 84 38 06768 38.

Our company provides, throughout the year, training courses allowing you to acquire the essential know-how for the implementation and maintenance of your equipment in order to guarantee its performance in the long term.

A catalog is available on request.

www.sames.com/france/fr/services-training.html



Line audits

As part of a technical assistance program for our customers using **Sames** equipment, the line audits are intended to help you optimize and control your production tool.

Our network of experts is continuously trained and qualified to provide our customers with technical expertise on the liquid or powder installations in which our equipment is integrated. The global environment of the production lines is taken into account during this technical audit.

A brochure is available for download:

www.sames.com/france/fr/services-service-contract.html



Maintenance program

An annual maintenance program (including or not the consumables to be replaced during each intervention) can be considered with the partnership of **Sames**. It is associated with a preventive maintenance plan established during a first audit visit which details the control points necessary to guarantee the performance of the installed equipment.

www.sames.com/france/fr/services-service-contract.html



Hotline

www.sames.com/france/fr/services-service-contract.html

Inogun M / Inogun M +

1. Health and safety instructions -----	6
1.1. Configuration of the certified equipment	6
1.1.1. Applicable Standards.....	6
1.2. Marking	7
1.3. Meaning of pictograms	9
1.4. Precautions for Use	10
1.5. Warnings	10
1.6. Regulatory tests to be carried out on the equipment according to standard EN 50050-2	12
1.7. Important recommendations	12
1.7.1. Ventilation.....	12
1.7.2. O-ring seals	12
1.7.3. Ambient temperature	12
1.8. Guarantee	13
2. Description -----	14
3. Characteristics -----	15
3.1. Dimensions (mm)	15
3.2. General characteristics	16
3.3. Air compressed quality	16
3.4. Operating principle	17
4. Diagrams -----	18
4.1. Electrical connections	19
5. Startup -----	20
5.1. Tools	20
5.2. Installation	21
5.2.1. Installation of an extended nozzle (option).....	21
5.2.2. Procedure for mounting the counter-electrode	22
6. Maintenance -----	23
6.1. Summary table of maintenance operations	23
6.2. Preventive maintenance plan - PMP 7132	24
6.3. Cleaning	24
6.3.1. Procedure A1: Spray gun cleaning.....	24
6.3.2. Procedure A2: Electrode support.....	25
6.4. Replacement	26
6.4.1. Procedure B1: Replacement of fixing hook.....	26
6.4.2. Procedure B2: Replacement of trigger	27
6.4.3. Procedure C1: Assembly / Disassembly barrel / handle	29
6.4.4. Procedure C2: Replacement of HVU.....	31
6.4.5. Procedure C3: Replacement of air connector o-rings.....	32
6.4.6. Procedure D1: Powder duct	33
6.4.7. Procedure D2: Replacement of low voltage cable	34
6.4.8. Procedure D3: Replacement of control box.....	36
7. Troubleshootings-----	38

8. Spare parts list -----	39
8.1. Manual spray guns	40
8.1.1. Inogun M spray gun	40
8.1.2. Inogun M + spray gun	42
8.2. Barrel assembly	44
8.3. Handle assembly	45
8.4. Electrode supports	46
8.4.1. Flat spray.....	46
8.4.2. Optional: Extended flat spray nozzle.....	47
8.4.3. Round spray.....	51
8.4.4. Option, Extended round spray nozzles	52
8.5. Counter-electrode assembly	56
8.6. Spray type conversion kits for extended nozzles	57
8.6.1. Kit for converting a flat spray into a round spray for extended nozzles	57
8.6.2. Kit for converting a round spray into a flat spray for extended nozzles	58
8.7. Additional equipment	59
9. Revision index History -----	60
10. Appendices -----	61
10.1. Preventive maintenance plan	61
10.2. EU and UK declarations of conformity	62

1. Health and safety instructions

This manual contains links to the following operating instructions:

- [see DRT7145](#) for the **Inobox** control module.
- [see DRT7134](#) for the **Inocontroller** control module.

1.1. Configuration of the certified equipment

All of these operating manuals define the configuration of the certified equipment.

1.1.1. Applicable Standards

The **Inogun M** guns has been designed according to standards indicated below:

Canadian Standards:

- CSA C22.2 No. 61010-1:12
- CSA C22.2 No. 213:19
- CSA C22.2 No. 0:20
- CSA C22.2 No. 60079-31:15 as a guide
- EN 50177:09 / A1:13 as a guide
- EN 50500-2:18 as a guide

US Standards:

- FANSI/ISA-61010-1: 3rd Ed.
- FM3600: 2018
- FM3611: 2018
- FM 7260: 2018 as a guide
- UL60079-31:2nd Ed. as a guide

Installation:

- In **Canada**, the installation has to be in compliance with the Canadian Electrical Code C22.1 part I, standard safety for electrical installations.
- In the **USA**, the installation has to be in compliance with the National Electrical Code NFPA 70.

1.2. Marking

The **Inogun M** and **Inogun M +** guns are classified as type "A-P" according to EN50050-2.

Marking of the guns:



The X sign placed after the EU/UK type examination certificate number indicates that this device is subject to special operating conditions:

- This equipment is designed for an ambient temperature range of 0°C to 40°C.
- During installation, the user should take into account that the keypad of the **Inobox** control module has only been subjected to a slight mechanical impact ([see DRT7145](#)).
- The **Inobox** control module must be protected from light.



"For Electrostatic Finishing Applications using Class II, spray material when configured according to 800004734", this statement may be abbreviated to read 'For Electro. Fin. Appl. CL. II, Spray Matl. when configured according to 800004734'.

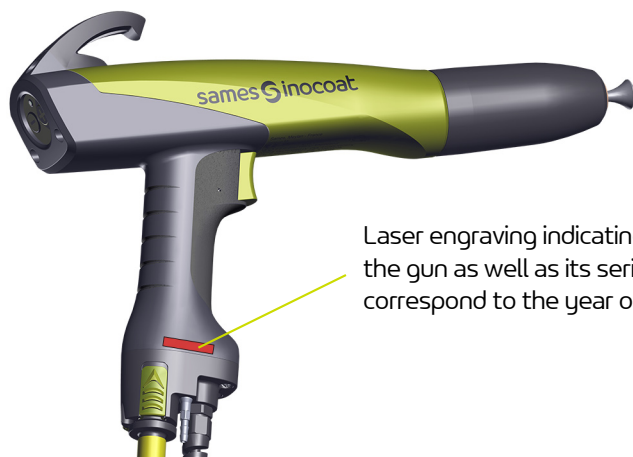

Laser engraving indicating the reference number of the gun as well as its serial number (the first 2 digits correspond to the year of manufacture)

* ATEX/UKCA **Inogun M** configurations

Inogun M spray gun - P/N 910030034 High Voltage Unit - P/N 910024679 Electrode support - P/N 910027640 Low voltage cable 6 m- P/N 910029134	Inogun M spray gun - P/N 910030034-12 High Voltage Unit - P/N 910024679 Electrode support - P/N 910027640 Low voltage cable 12 m- P/N 910029182	Inogun M spray gun - P/N 910030034-18 High Voltage Unit - P/N 910024679 Electrode support - P/N 910027640 Low voltage cable 18 m- P/N 910029982	P/N Inogun M (*)	Inobox P/N 910029983 P/N 910029984 P/N 910030576	Inocontroller P/N 910028596
X			910030034	X	X
	X		910030034-12	X	X
		X	910030034-18	X	X

* ATEX/UKCA **Inogun M +** configurations

Inogun M + spray gun - P/N 910031951 High Voltage Unit - P/N 910031489 Electrode support - P/N 910027640 Low voltage cable 6 m- P/N 910029134	Inogun M + spray gun - P/N 910031951-12 High Voltage Unit - P/N 910031489 Electrode support - P/N 910027640 Low voltage cable 12 m- P/N 910029182	P/N Inogun M + (*)	Inobox P/N 910029983 P/N 910029984 P/N 910030576	Inocontroller P/N 910028596
X		910031951	X	X
	X	910031951-12	X	X

1.3. Meaning of pictograms

				
Warning electricity	Warning Automatic start-up	Warning Hot surfaces	Warning Explosive material	General warning sign
				
Warning High pressure	Warning Crushing of hands	Warning for explosive atmospheres	Warning: Flammable material	Warning: Corrosive substance
				
Warning: Toxic material	Warning Harmful products	No access for people with active implanted cardiac devices	Wear ear protection	Wear a face shield
				
Wear respiratory protection	Wear safety footwear	Wear protective clothing	Wear protective gloves	Wear head protection
				
Opaque eye protection must be worn	General mandatory action sign	Connect an earth terminal to the ground	Refer to Instruction manual	

1.4. Precautions for Use

This document contains information that all operators should be aware of and understand before using the spray gun. This information highlights situations that could result in serious damage and indicates the precautions that should be taken to avoid them.



Before any use of the projector, check that all operators:



- have previously be trained by the company Sames, or by their distributors registered by them for this purpose.
- have read and understood the user manual and all rules for installation and operation, as laid out below.



It is the responsibility of the operators' workshop manager to ensure these two points and it is also his responsibility to make sure that all operators have read and understood the user manuals for any peripheral electrical equipment present in the powdering area.

1.5. Warnings



It is imperative that anyone wearing a pacemaker does not use the equipment and does not enter the projection area. High voltage can cause the pacemaker to malfunction.



Safety may be jeopardized if this equipment is not operated, disassembled and reassembled in compliance with the instructions given in this manual and in any European Standard or national safety regulations in force.



Equipment performance is only guaranteed if original spare parts distributed by Sames are used.



To guarantee an optimal assembly, spare parts must be stored in a temperature close to their temperature of use. Should the opposite occur, a sufficient waiting time must be observed before the installation, so that all the elements are assembled in the same temperature.



This equipment is intended for spraying powder paint only.



This equipment must only be used in powdering locations according to standard EN 50050-2 and EN 16985. The equipment has to be used only within ventilated in order to reduce risks for the health of the operators, fire or explosion. The efficiency of the extraction ventilation system has to be daily checked.

Within explosive atmospheres produced by the spraying process, only appropriate explosion-proof electrical equipment has to be used.

- 1 The operator must wear shoes according to standard EN ISO 20344 and the insulation resistance measured must not exceed 100 M Ω .
- 2 The protective clothes, including gloves, must conform to standard EN 1149-5 and the insulation resistance measured must not exceed 100 M Ω .
- 3 Using individual protection equipment will limit the risks of contact and/or inhalation of toxic product, gas, vapours, fog or dusts that can be produced while using the equipment. The user has to follow the coating product manufacturer's recommendations.
- 4 Contact or inhalation of the products used with this equipment may be dangerous for personnel (see: safety data sheets for the products used). The pressure coating material or compressed air must not be directed at people or animals.
- 5 The parts to be painted must have a resistance to earth less than or equal to 1 M Ω (measurement voltage of at least 500V or 1000V) (§6.2.2.4 in Standard EN 50050-2). This must be checked regularly.
- 6 All conductive structures such as floors, powder spray station walls, ceilings, barriers, barriers, parts to be painted, powder dispensing tank placed in or near the work area and the ground terminal of the electro-pneumatic control module must be electrically connected to the grounding system for protecting the power supply.
- 7 The floor on which the operator works must be dissipative (bare concrete floor or metal grating). Never cover the floor with an insulating covering. In potentially explosive locations, floor assemblies must be dissipative in accordance with EN 61340-4-1.
- 8 Switch off the power supply to the **Inobox** before connecting the **Inogun M** guns.
Before disconnecting the gun, cut off the power supply to the **Inobox** (otherwise a malfunction may occur).
- 9 It is essential to properly ventilate the spray booths to avoid any powder output and to ensure a powder concentration below the lower explosive limit (LEL). The associated equipment must be placed outside the hazardous areas and its commissioning must be controlled by the operation of the cabin suction fan.
- 10 Never point the gun at a person or animal.
- 11 Powder spraying must be carried out in front of a ventilated station provided for this purpose. The activation of the **Inobox** must be controlled by the operation of the ventilation system. The correct operation of the drive must be checked once a week.
- 12 The ambient operating temperature must be between 0 and 40°C.
- 13 The electrostatic powder spraying equipment must be maintained regularly in accordance with the indications and instructions given by **Sames**.
Repairs must be carried out in strict accordance with these instructions.

14 The electrostatic powder spraying equipment should only be operated if it is in perfect condition. Damaged equipment must be removed from service immediately and repaired.

15 Before cleaning the projectors or doing any other work in the spray area, the power supply to the high-voltage generator must be disconnected, protected against restarting and the HV circuit protected. (projector) discharged to ground.
Cleaning must be carried out in mechanically ventilated areas.

16 Inside the booth it is forbidden to use naked flames, glowing objects or devices likely to produce sparks. It is also forbidden to store flammable products, or recipients that have contained them, in the vicinity of the booth.
The surrounding area must be kept clear and clean.

17 In the explosive zone, it is forbidden to use non-certified electrical or non-electrical equipment such as electrical extension cords, multi-sockets, switches, etc.

A warning sign in a language understood by the operator, summarizing the safety rules described above, must be prominently displayed in the vicinity of the powder spray station.

1.6. Regulatory tests to be carried out on the equipment according to standard EN 50050-2

The tests must be carried out on the spraying equipment. The tests must be carried out by competent personnel and include the tests described below (see § 6.2.3 table 1 in standard EN 50050-2).

Type of test	Requirements
Grounding measures	Weekly
Forced ventilation interlock and manual electrostatic spraying equipment	Annual
Checking manual electrostatic spraying equipment for damage	Weekly

(*) Intervals depend on operating and local conditions.

1.7. Important recommendations

1.7.1. Ventilation

Do not start the powder application with the **Inogun M** spray gun until the spray booth ventilation system is switched on. If the ventilation is switched off, toxic substances or dust may remain in the spray booth and cause a risk of fire, poisoning or irritation.

1.7.2. O-ring seals

Use the seals recommended in this manual.

1.7.3. Ambient temperature

The spray gun is designed to normally operate at an ambient temperature comprised between 0°C and + 40°C. The storage temperature must never exceed +60°C.

1.8. Guarantee

Under the guarantee, which applies only to the buyer, **Sames** agrees to repair operating faults resulting from a design fault, materials or manufacture, under the conditions set out below.

The guarantee claim must define the exact nature of the fault concerned, in writing.

The **Sames** guarantee only covers equipment that has been serviced and cleaned according to standard procedures and our own instructions, that has been fitted with parts approved by **Sames** or that has not been modified by the customer.

More precisely, the guarantee does not cover damage resulting from:

- the customer's negligence or inattention,
- incorrect use,
- failure to follow procedures,
- use of a control system not designed by **Sames** or a **Sames** control system modified by a third party without written permission from an authorized **Sames** technical agent,
- accidents such as: collision with external objects, or similar events,
- flooding, earthquake, fire or similar events,
- use of seals not complying with **Sames** recommendations,
- pollution of air circuits by fluids or substances other than air.

The **Sames** guns type **Inogun M / M +** are covered by a warranty (refer to the general sales conditions for its application).

The guarantee does not apply to wearing parts such as electrode supports, deflectors, powder tube, seals, etc...

The guarantee will take effect from the date of the first start-up or of the provisional acceptance report.

Under no circumstances, either in the context of this guarantee or in other contexts, will **Sames** be held responsible for physical injury or intangible damage, damage to brand image and loss of production resulting directly from its products.

2. Description

The **Inogun M** guns is a manual gun designed to project powder by means of a high voltage unit integrated in the gun which delivers up to 100 kV and 110 µA.. It is associated with an **Inobox** or **Inocontroller** control module which controls both the high voltage and the powder flow rate of the gun connected to it. These two inseparable elements constitute a manual powder coating equipment.

This new gun integrates a dual control by the + and - keys located on the rear keyboard which allow to adjust powder flow, current or change of the program according to the selection on the **Inobox** module ([see DRT7145](#)) when pressing the keyboard.

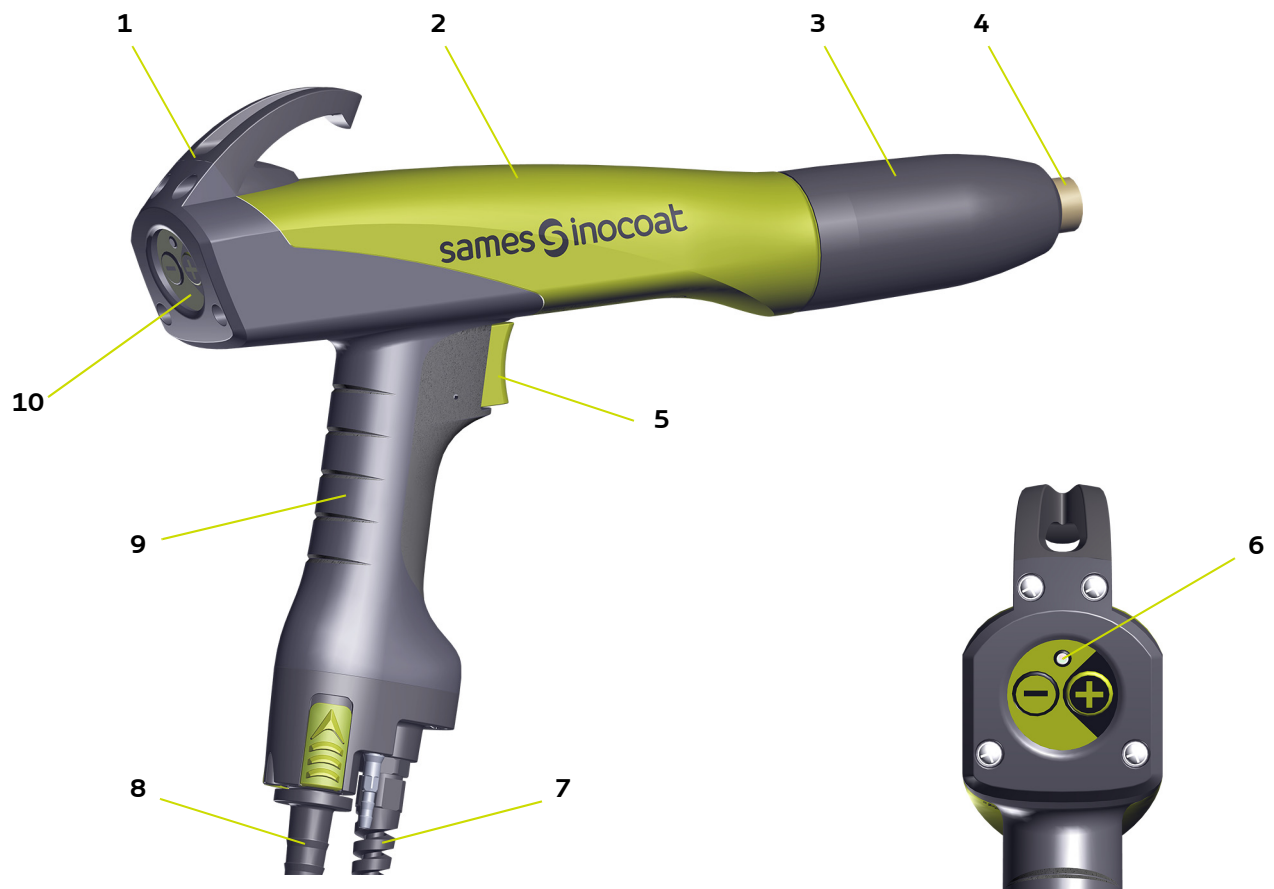

Item	Description
1	Fastening hook
2	Barrel
3	Nozzle nut
4	Flat spray deflector
5	Trigger
6	High voltage presence LED
7	Low voltage cable
8	Powder fitting
9	Handle
10	Control box

3. Characteristics

3.1. Dimensions (mm)

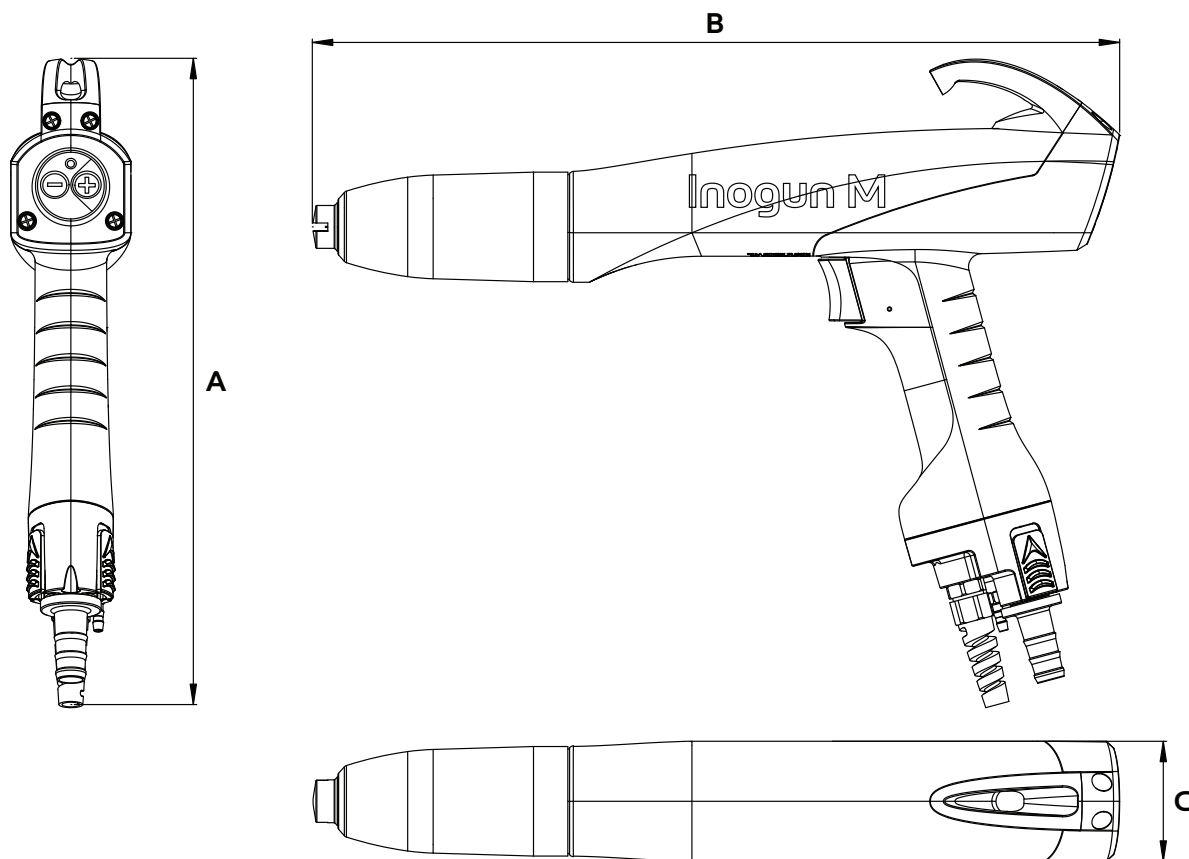

DES07478

	mm	inches
A	271	10.67
B	339	13.35
C	50	1.97

3.2. General characteristics

Inogun M / M+ spray guns	
Ambient temperature during operations	0° to 40°C
Maximum operating altitude	2000 m
Weight of the gun (without cable and hose)	565 g
Maximum output voltage negative HVU	-100 kV (0 kV, -10 kV)
Maximum output voltage positive HVU	+100 kV (0 kV, -10 kV)
Max. output current	110 µA (+ or - 10 µA)
High voltage unit capacity	60 pF
Supply pressure	7 bar +/- 1 bar
Maximum powder flow rate	24 kg/h
Maximum relative humidity of 80% for temperatures up to 31°C, and linear decrease to 50% relative humidity at 40°C.	maximum 80% non-condensing
Storage / Transport	
Storage duration	Max. 2 years
Minimum/maximum storage temperature	-10°C + 45°C
Humidity	95% non-condensing
Min. pressure	750 mBar
Exposure to UV radiation	Stored away from light
Exposure to ionizing radiation	Not admitted

3.3. Air compressed quality

Characteristics of compressed air supply according to the standard NF ISO 8573-1:

Maximum dew point at 6 bar (87 psi)	Class 4 i.e + 3°C (37°F)
Maximum particle-size of solid pollutants	Class 3 i.e 5 µm
Maximum oil concentration	Class 1 i.e 0,01 mg/m ³ *
Maximum concentration of solid pollutants	Class 3 i.e 5 mg/m ³ *

*: Values are given for a temperature of 20 °C (68 °F) at an atmospheric pressure of 1 013 mbar.



Non-compliance with these characteristics may result in incorrect operation of the Inocontroller or Inobox control modules.



A 5 µm filter must be installed upstream of the compressed air supply of the Inocontroller or Inobox control modules. This filter is sized according to the size of the installation. Sames recommends using a filter of the type indicated in the section ([see § 8.7 page 59](#)). In the event of damage to the equipment due to the use of polluted air, the warranty may not be applied.

3.4. Operating principle

By pulling the gun trigger, the power supply and electrical charging of the powder is triggered.

Keys  et  on the back keyboard are used to adjust:



- Powder flow when simultaneously pressing the trigger and the keyboard.
- The current or change of the program according to the selection on the **Inobox** module ([see DRT7145](#)) when pressing the keyboard.

4. Diagrams

Synoptic of an installation with **Inogun M** and **Inobox**

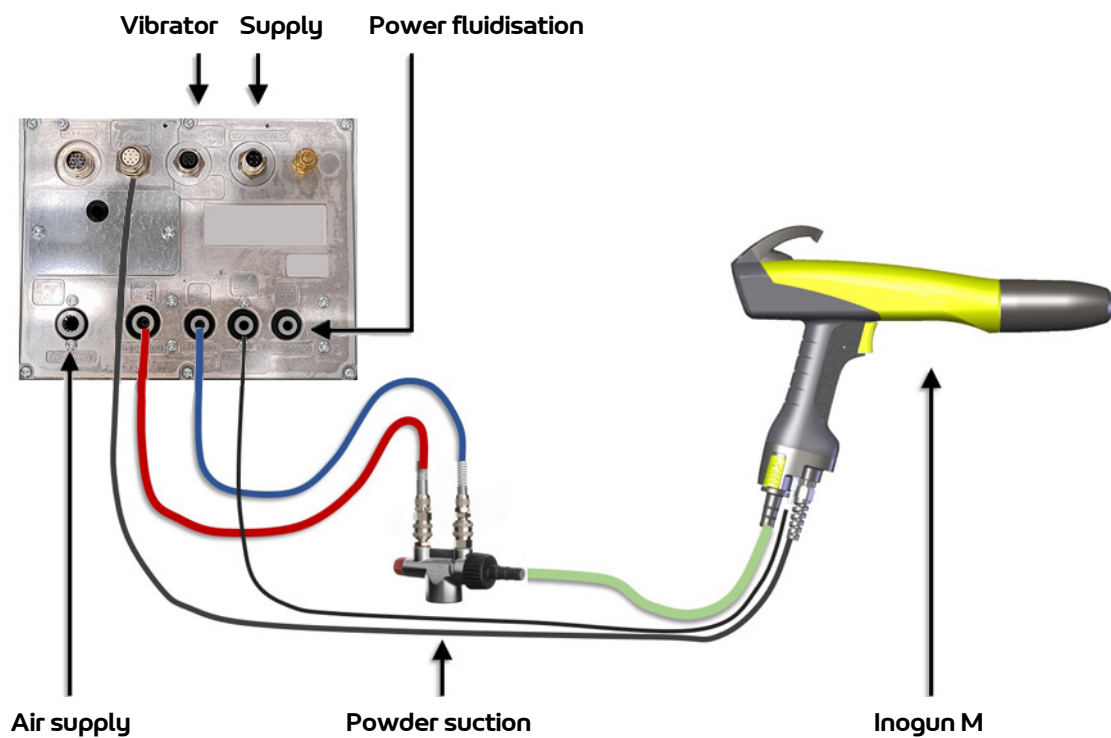

Synoptic of an installation with **Inogun M** and **Inocontroller**

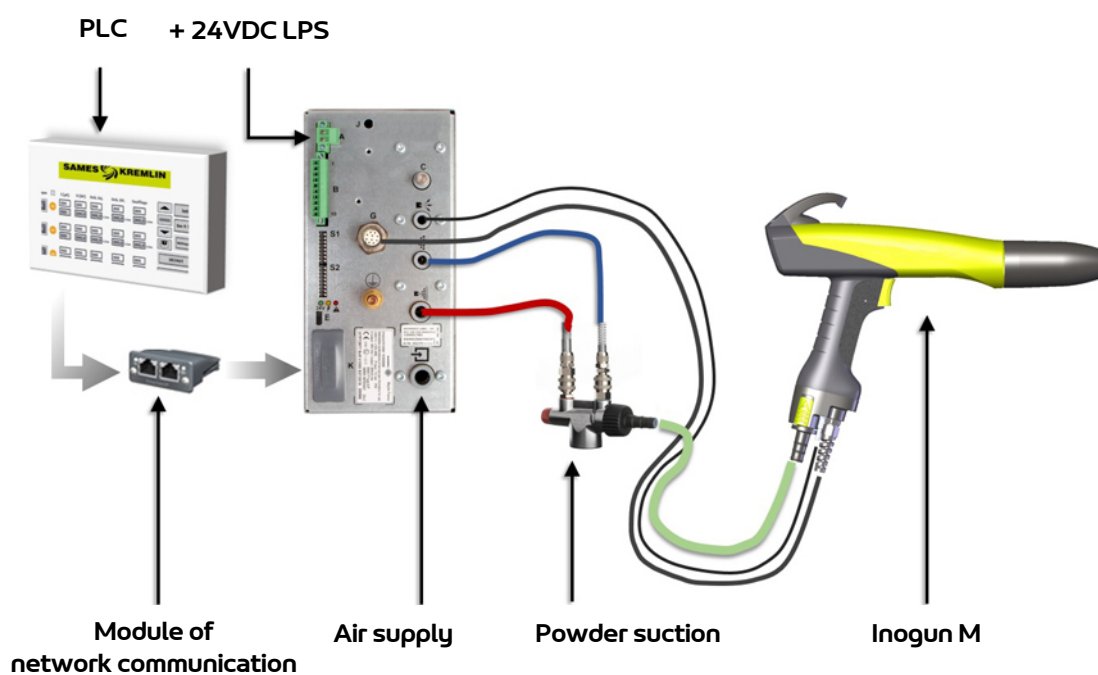

The **Inogun M** guns are connected to the **Inobox** or **Inocontroller** control module. This module provides the low-voltage and high-frequency power supply necessary for the operation of the integrated high-voltage unit and the air distribution and regulation.

4.1. Electrical connections

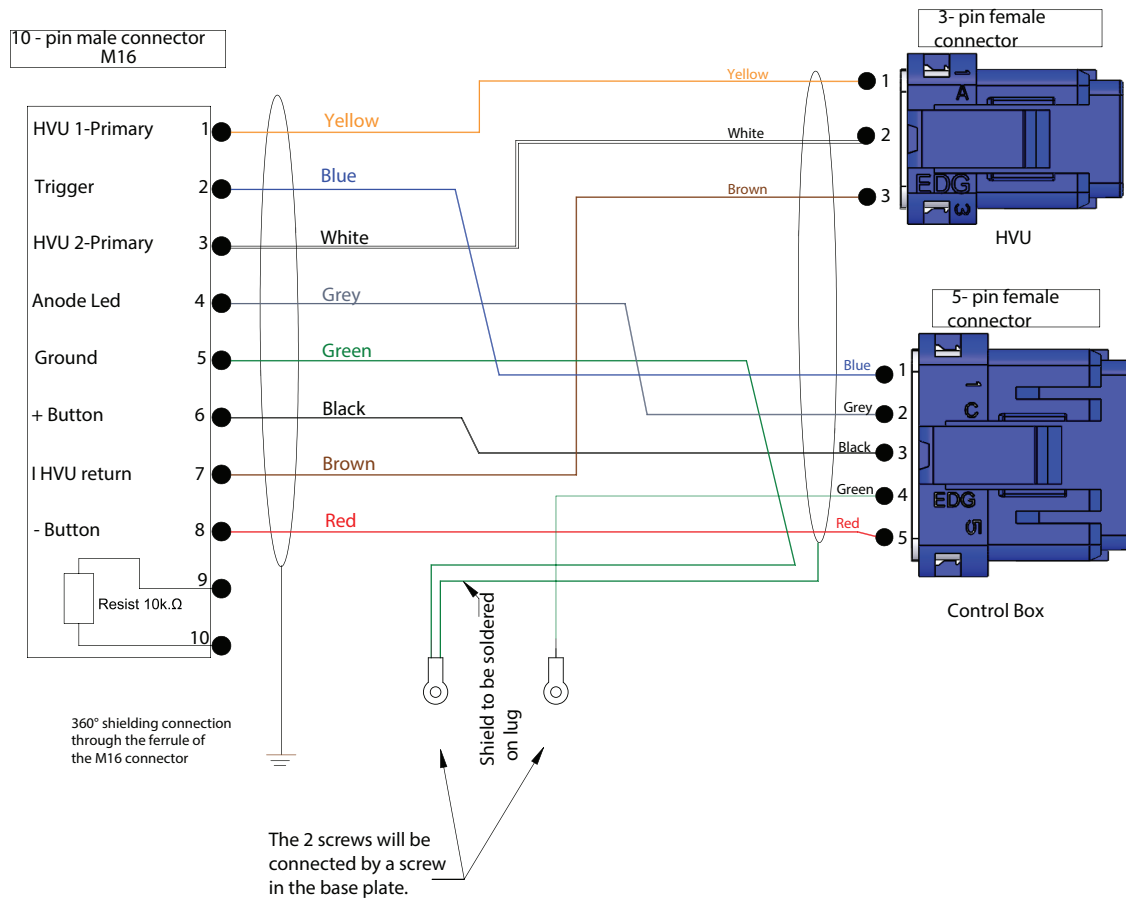

DES07803

Pin	10-pin connector Inobox side	Pin	3-pin connector Inogun M side	Pin	5-pin connector Inogun M side
1	HVU 1-Primary	1	HVU 1-Primary		
2	Trigger			1	Trigger
3	HVU 2-Primary	2	HVU 2-Primary		
4	Anode LED			2	Anode LED
5	Ground			4	Ground
6	+ Button			3	+ Button
7	I HVU return	3	I HVU return		
8	- Button			5	- Button
9					
10	10kW resistor				

5. Startup

5.1. Tools

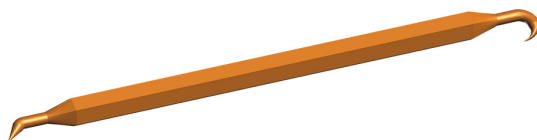

P/N	Description	Qty	Unit of sale
240000301	Seal extractor tool	1	1



P/N	Description	Qty	Unit of sale
H1GMIN017	White Vaseline (100 ml)	1	1
H1GSYN037	Dielectric grease for high voltage unit (100 ml)	1	1

Additional tools and accessories required:

The tools listed below should be available for product installation and maintenance operations.

- Flat screwdriver (0.6x3.5).
- 2- Pozidriv screwdriver.
- Torque wrench.
- Open-end wrench (15 mm).
- Multigrip pliers.

5.2. Installation

The **Inogun M** guns are installed either on the different types of cart (vibrating table, tank or penetrant testing) or on a manual station of a booth (see corresponding operating manuals).

5.2.1. Installation of an extended nozzle (option)

The **Inogun M** guns can be equipped with optional extended nozzles for flat spray and round spray ([see § 8.4.2 page 47](#) and [see § 8.4.4 page 52](#)).

- Switch off high voltage,
- **Step 1:** Manually unscrew the nozzle nut (1),
- **Step 2:** Remove the electrode support assembly (3) and its flat jet or round jet deflector (2).

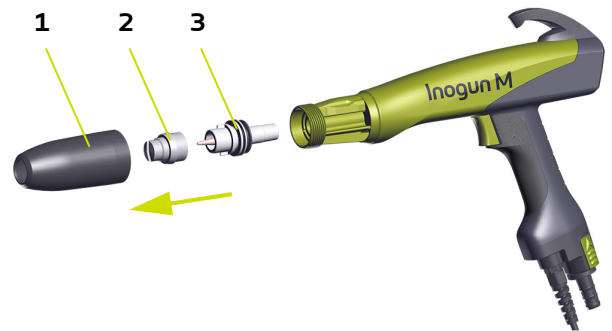

When installing an extended nozzle from length 450 mm, it is imperative to check the presence of the reinforcing sleeve (4) (P/N 900020899) in the reinforcing electrode support ([see § 8.4.4 page 52](#)).

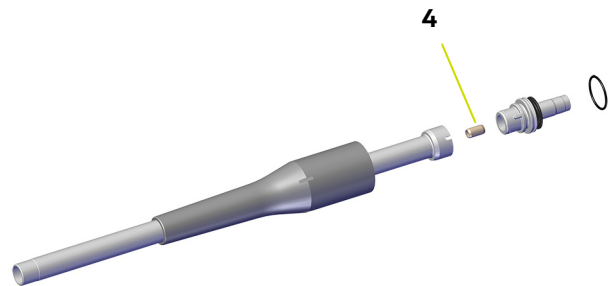

- **Step 3:** Install the extended nozzle assembly (5) into the gun barrel.
- **Step 4:** Manually screw the new extended nozzle nut (6).
- **Step 5:** Install the deflector (7).
- Switch on high voltage.

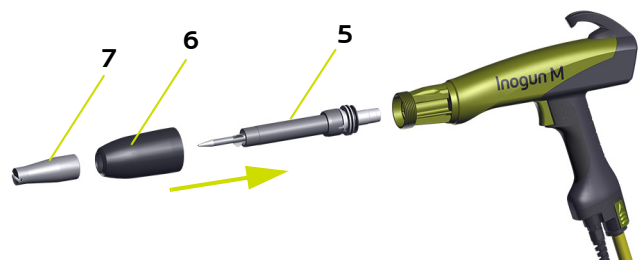

5.2.2. Procedure for mounting the counter-electrode

The **Inogun M** can be equipped with an optional counter-electrode ([see § 8.5 page 56](#)).

- Switch off high voltage,
- **Step 1:** Unscrew the 2 screws (1 and 2) at the back of the gun.



- **Step 2:** Slide the hook towards the front of the gun.



- **Step 3:** Insert the conductive hook (3), slide it to the stop and then tighten the 2 KA 30 x 20 screws (4) to a torque of 0.65 N.m.

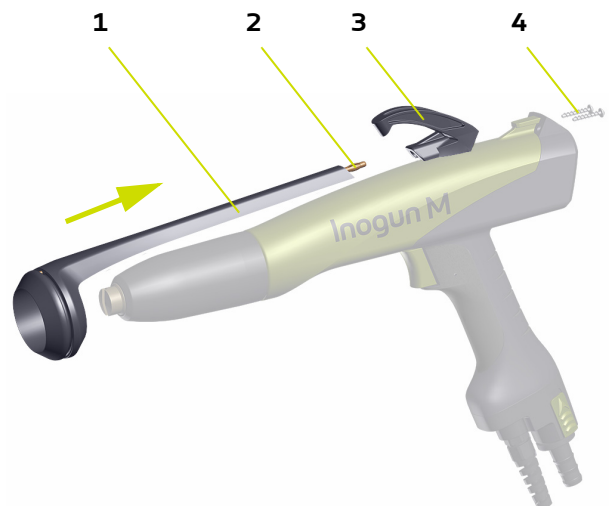

- **Step 4:** Place the counter-electrode (1) on the nozzle nut of the gun and slide it until the banana plug (2) is in contact with the conductive hook (3).

- Switch on high voltage.

6. Maintenance

Preventive maintenance is an essential part of production and ensures the reliability of the installation. As a reminder, the performance of equipment can only be guaranteed if a minimum of control and cleaning operations are performed on this equipment.



Soiling and wear of the Inogun M gun caused by the passage of powder depend on the operating and application conditions and the production rates.



Switch off the power supply to the control module before connecting the spray gun. Before disconnecting the spray gun, switch off, disconnect the power supply to the Inocontroller or Inobox (otherwise, a malfunction may occur).



Never throw or intentionally drop the gun. Dropping the gun could damage the high-voltage unit. After a fall, it is recommended to check the operation of the gun out of the area before re-use and its condition.

6.1. Summary table of maintenance operations

The maintenance intervals indicated in the procedures below are only indicative. The user will have to create his own maintenance schedule as he use **Sames** equipment.

Procedure		Detail	Duration	Frequency
Cleaning				
A	A1	Cleaning of spray gun exterior	2 min	8 Hours
	A2	Cleaning of electrode support and deflector	2 min	8 Hours
Replacement				
B	Spray gun maintenance			
	B1	Replacement of fixing hook	2 min	-
	B2	Replacement of trigger	5 min	-
C	Barrel maintenance			
	C1	Assembly / Disassembly barrel / handle	5 min	-
	C2	Replacement of HVU	5 min	-
	C3	Replacement of air connector o-rings	5 min	-
D	Handle maintenance			
	D1	Powder duct	2 min	-
	D2	Replacement of low voltage cable	5 min	-
	D3	Replacement of control box	5 min	-

6.2. Preventive maintenance plan – PMP 7132

see § 10.1 page 61

The objective of the proposed preventive maintenance plan is to define in an exhaustive way, the verification, replacement and cleaning actions of the installed Sames equipment.

In order to anticipate breakdowns and malfunctions that may be due to technical deviations of the installation, the preventive maintenance plan attached to the user manual lists the routine maintenance operations necessary for better comfort in the use of the production tool.

Depending on the skills, area of responsibility and accreditation of each person involved, the preventive maintenance plan can be divided into two distinct levels: level 1 and level 2:

- **Level 1:** first level maintenance is essentially composed of visual control and cleaning operations of some elements of the equipment. To limit this level, only the specific tools supplied with the equipment will be used. This first level of maintenance is generally taken care of by paint operators or installation managers.
- **Level 2:** second level maintenance completes the first level by more complex dismantling operations requiring electrical engineering tools. This second level is generally handled by the factory maintenance department.

6.3. Cleaning

These maintenance operations can be performed online. Before any intervention, refer to the health and safety instructions ([see § 1.5 page 10](#)).

6.3.1. Procedure A1: Spray gun cleaning



Always wear safety glasses.



When handling powder, wear gloves of a suitable resistant material



Work in a well ventilated area.



**All cleaning operations should only be carried out with compressed air expanded to a maximum pressure of 2.5 bar, a cloth or possibly a brush.
Never use water or solvents to clean the equipment.**

- Clean the spray gun with compressed air every 8 hours..

6.3.2. Procedure A2: Electrode support.

- Switch off high voltage,
- **Step 1:** Manually unscrew the nozzle nut then remove the deflector.
- **Step 2:** Remove the electrode support.
- **Step 3:** Clean the electrode support with compressed air and also the deflector
Make sure that there is no accumulation of powder.
- **Step 4:** Clean the powder passage duct by blowing with compressed air.
- **Step 5:** Before reassembling the electrode support, clean the electrical contact with compressed air located in the gun.
Check the condition of the O-rings, replace them if necessary.



6.4. Replacement

6.4.1. Procedure B1: Replacement of fixing hook

- **Step 1:** Unscrew the 2 screws at the back of the gun.



- **Step 2:** Slide the hook towards the front of the gun.



- **For reassembly:** Fit the new hook, slide it in until it stops and tighten the 2 screws KA 30 x 20 to a torque of 0.65 N.m.

6.4.2. Procedure B2: Replacement of trigger

- Using a pin punch D: 1.8 mm, pull the trigger pin out of the trigger in the handle.

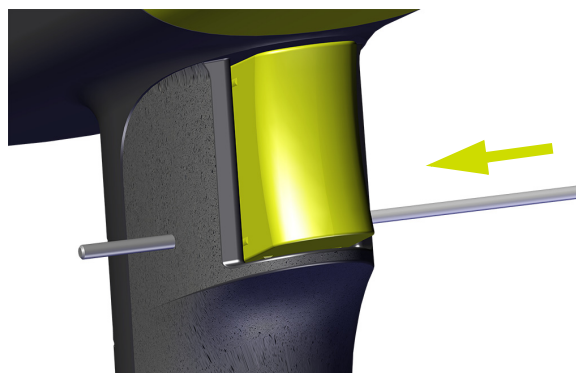

Remove the trigger.
Be careful not to lose the spring.

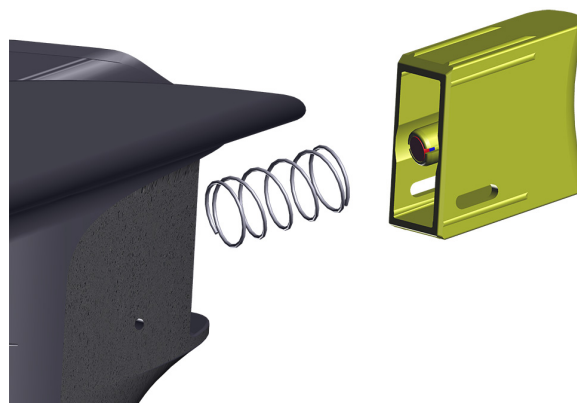

- Replacing the trigger:** The pin (C) must be correctly centered,
 - Place the spring (A) around the magnet (B).
 - Place the trigger in its housing as shown.
 - Insert the pin (C).

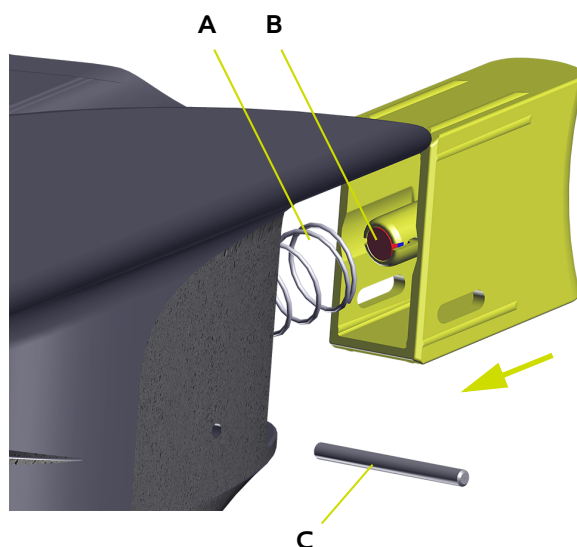

4 Push it in with the pin punch, it must be correctly centred

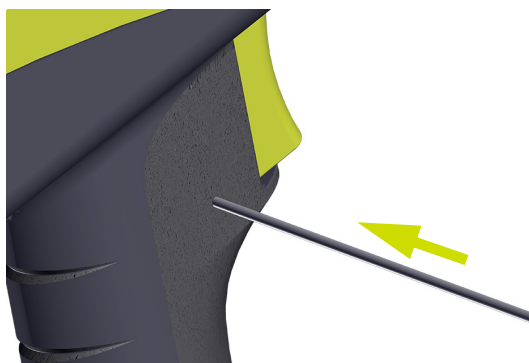

and don't go out either way.

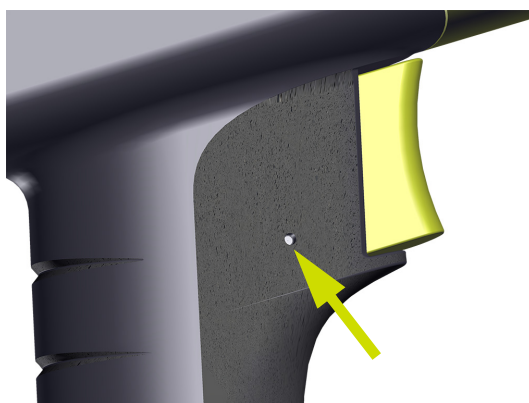

5 Check that the trigger is working properly without hard points and/or noise.

6.4.3. Procedure C1: Assembly / Disassembly barrel / handle

- **Step 1:** Unscrew the 4 screws at the back of the gun.



- **Step 2:** Separate the handle from the barrel by simultaneously making small horizontal and vertical movements.



- **Step3:** Remove the connector (1) from the cable guide clip (P/N: 900020680) (2) and disconnect the connector from the HVU.

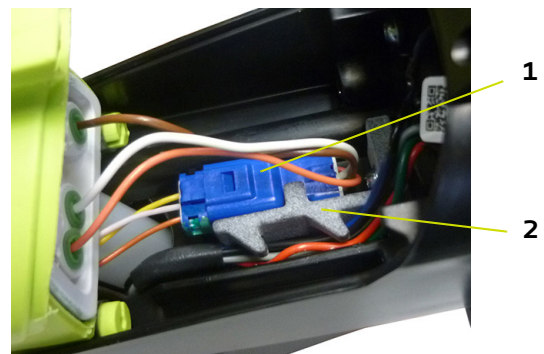

- Handle and barrel are separated.

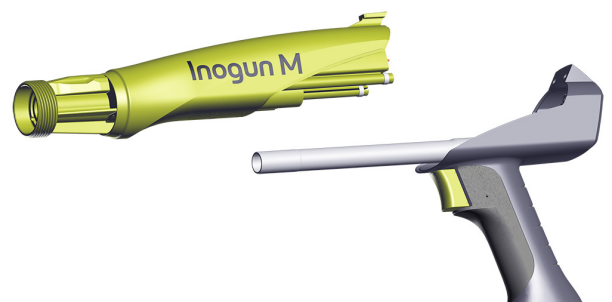

• **Step 4: Reassembly of the barrel/handle:**

1 Put a light coat of Vaseline in the powder channel duct to facilitate its reassembly.

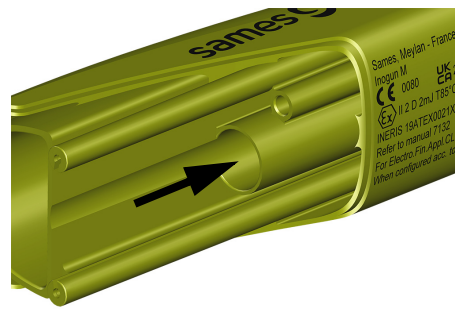

2 Insert the powder duct, connect the HVU.

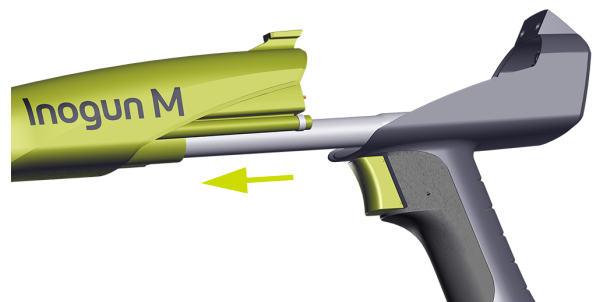

3 Place the connector (1) under the UHT, wedge it under the cable guide clip (2),

make sure that the wires loop over the connectors.

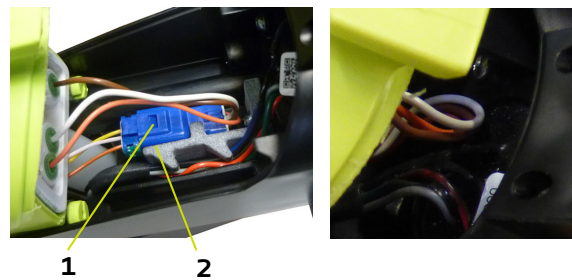

4 Place the barrel against the handle, starting with the upper part and then the lower part.



5 Place then screw in the 4 screws and washers, and tighten crosswise with a torque of 0.65 N.m.



6.4.4. Procedure C2: Replacement of HVU

- Unscrew the HV contact.

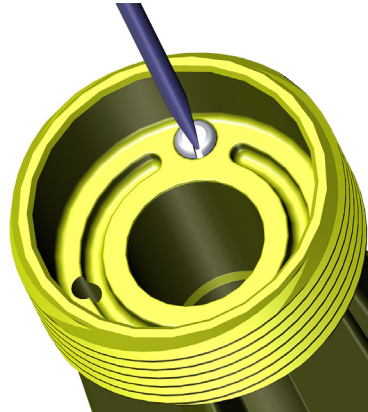

- Using a multigrip pliers, extract the HVU from the barrel.

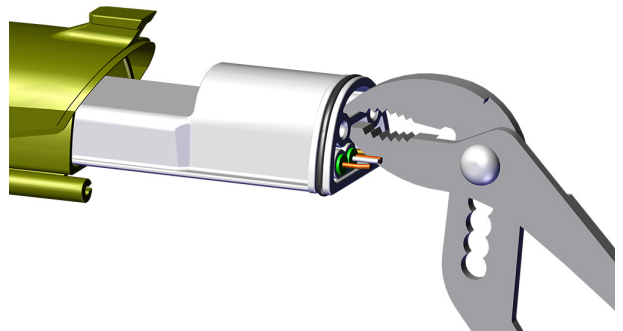

- Replace the HVU, apply a light coat of dielectric grease (P/N H1GSYN037) to the seal of the new HVU.

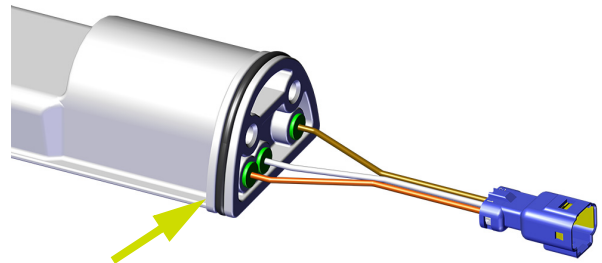

- Position the HVU in the gun and push it to the stop.
- Place a plug with a layer of dielectric grease on the HV contact seal. Screw it to the contact + 1/4 turn. Make sure to leave a slight protrusion of the screw head in relation to the surface of the barrel.

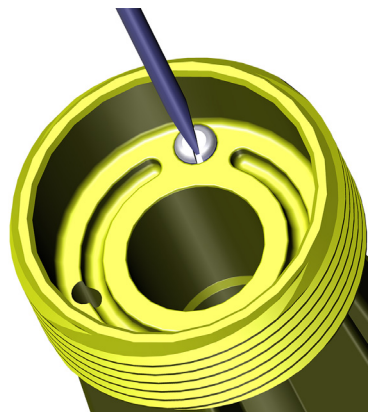

6.4.5. Procedure C3: Replacement of air connector o-rings

- **Step 1:** Using a flat screwdriver, extract the air connector from the barrel.

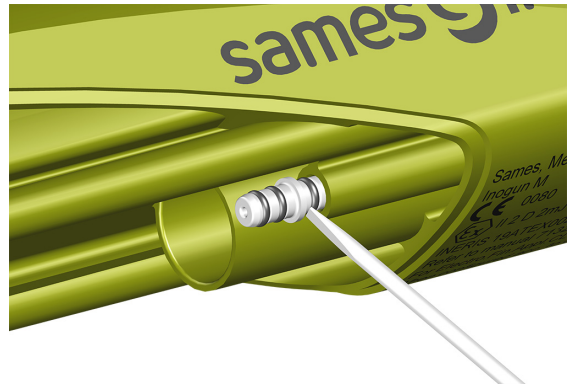

- **Step 2:** Using the tool (P/N 240000301), remove the o-rings of the air connector one by one.



- **Step 3: Replacement**
Manually install new o-rings on the air connector, starting with the 2 o-rings (Item 1) and then the 2 others (Item 2).
Then reinsert the air connector into the barrel.

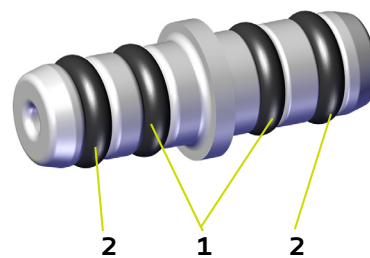

6.4.6. Procedure D1: Powder duct

- **Step 1:** Extract the powder duct from the handle.

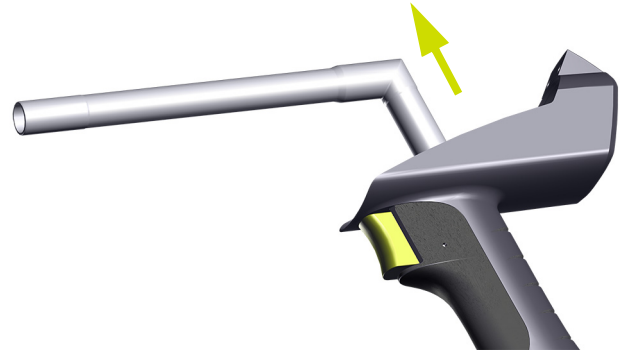

- **Step 2: Reassembly**

- 1 Clean the inside of the powder duct with compressed air.
- 2 Check the condition of the seal and the powder duct, change them if necessary.
- 3 Insert the duct from the top of the handle, taking care to place the wires on the side opposite the air duct (the wires must not touch the sharp angle of the handle).



6.4.7. Procedure D2: Replacement of low voltage cable

- **Step 1:** Push the 2 bolts so that the powder hose can be unlocked and removed.

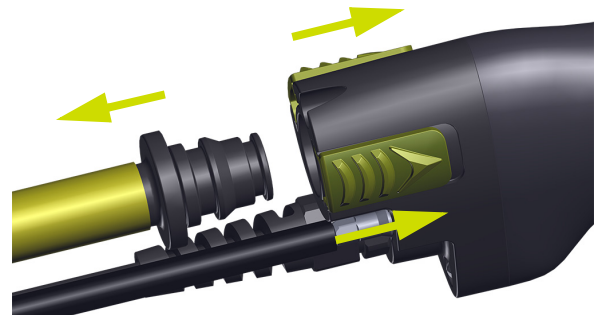

- **Step 2:** Remove the air hose.

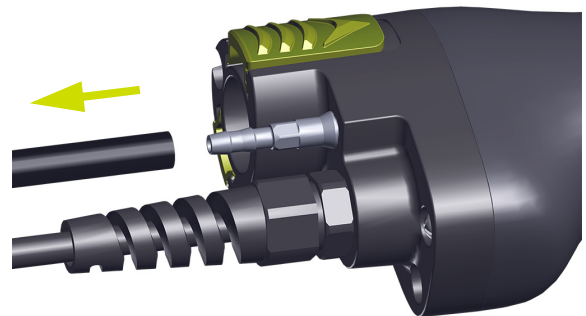

- **Step 3:** Loosen the 3 screws.

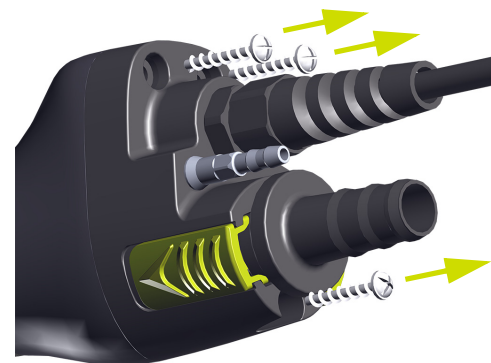

- **Step 4:** Remove the base plate from the handle and disconnect the blue connector from the control box.



• **Step 5: Replace the LV cable.**

1 Insert the connector (1) connecting the HVU into the handle. Leave enough space to correctly reposition the powder duct.

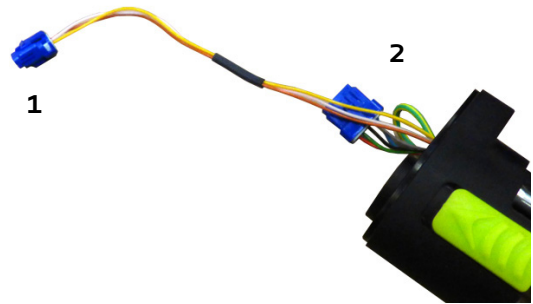

2 Insert the powder duct into the handle, making sure not to pinch the wires.

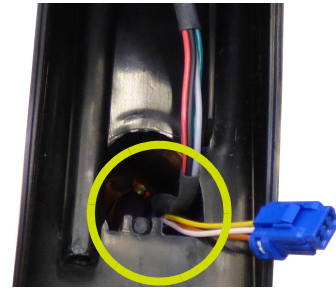

3 Connect the blue connector (2) connecting the control box.



4 Position the base plate on the handle. Push the powder duct onto the base plate.

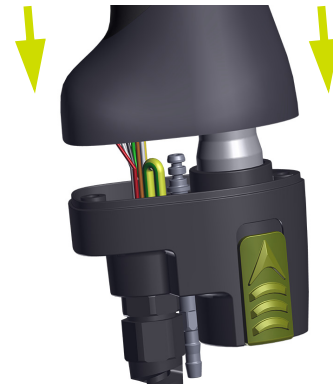

5 Screw then tighten the assembly with the 3 KA 30 screws and washers on the handle with a torque of 0.65 N.m.

6 Reconnect the powder and air hoses.

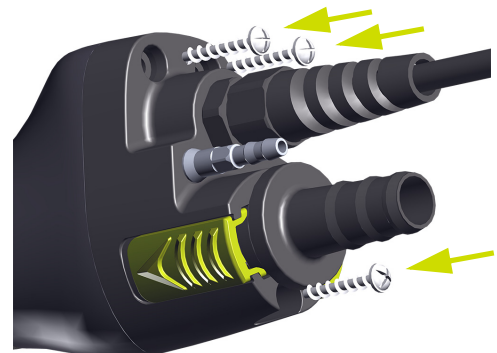

6.4.8. Procedure D3: Replacement of control box

By having previously followed steps 1 to 4 of procedure D2 ([see § 6.4.7 page 34](#)),

- **Step 1:** Unscrew the 5 screws, take the housing out of its housing.

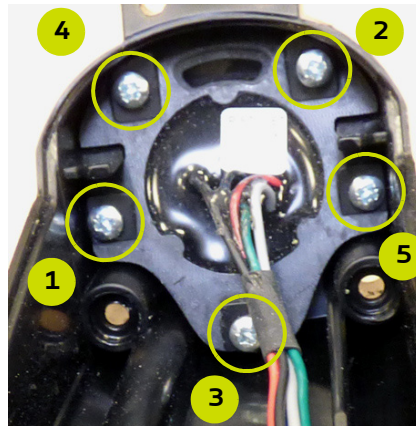

- **Step 2:** Using the tool (P/N: 240000301) push the reed light outwards.



- **Step 3:** Pull the control box out of the handle.

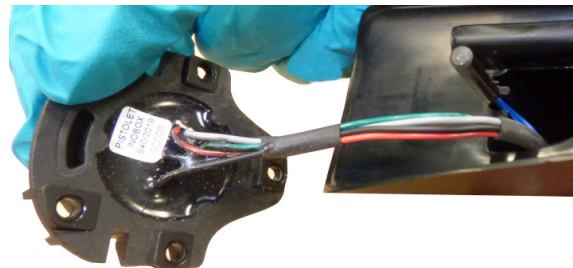

- **Step 4:** Control box replacement

- 1 Push the plug into the grip of the handle

- 2 Insert the REED light into its housing with the wires facing down as far as they will go.



- 3 Place the wires on the opposite side of the air channel.



- 4 Place the control box at the bottom of the handle.

- 5 Screw then tighten the 5 screws KA30x10 crosswise to a torque of 0.45 N.m.

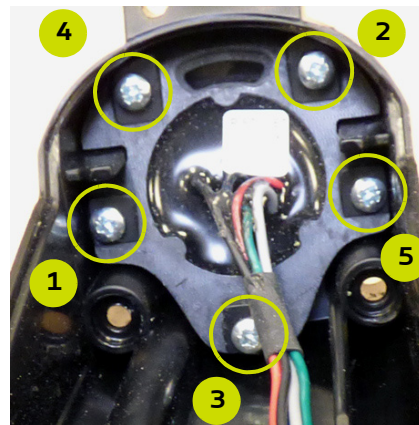

- 6 Then follow steps 3 to 6 of step 5 of procedure D2 ([see § 6.4.7 page 34](#)).

7. Troubleshooting

Symptoms	Probable causes	Remedies
Powder flow drop	Soiling of the powder duct	Disassemble the gun, clean it or change the duct.
	Plugging of the powder supply hose	Clean the powder hose with compressed air.
	Wear and tear clogging of the powder pump	Refer to the powder pump instruction manual.
Powder does not adhere to the part.	No high voltage: - Bad connection of the HVU due to assembly / disassembly	Check the electrical connections of the HVU
	- Cut low voltage cable	Change the low voltage cable
	Incorrect setting of U/I	Use "factory" settings
	Incorrect pneumatic setting	Use "factory" settings

8. Spare parts list

The spare parts are classified in 2 different types:

- **1st emergency parts:**

The 1st emergency parts are strategic components which are not necessarily consumables but which in case of failure prohibit the operation of the equipment.

Depending on the production line's commitment and the production rates imposed, the first emergency parts are not necessarily kept available in the customer's stock.

Indeed, if an interruption of the production flow is possible, storage is not necessary.

On the other hand, if the stop is not possible, the 1st emergency parts will be kept in stock.

- **Wearing parts:**

Wearing parts are consumable components such as O-rings that undergo regular degradation over time during normal operation of the installation. It is therefore advisable to replace them according to a defined frequency and adapted to the operating time of the installation.

The wearing parts must therefore be kept in the customer's stock.



To guarantee an optimal assembly, spare parts must be stored in a temperature close to their temperature of use. Should the opposite occur, a sufficient waiting time must be observed before the installation, so that all the elements are assembled in the same temperature.

8.1. Manual spray guns

8.1.1. Inogun M spray gun

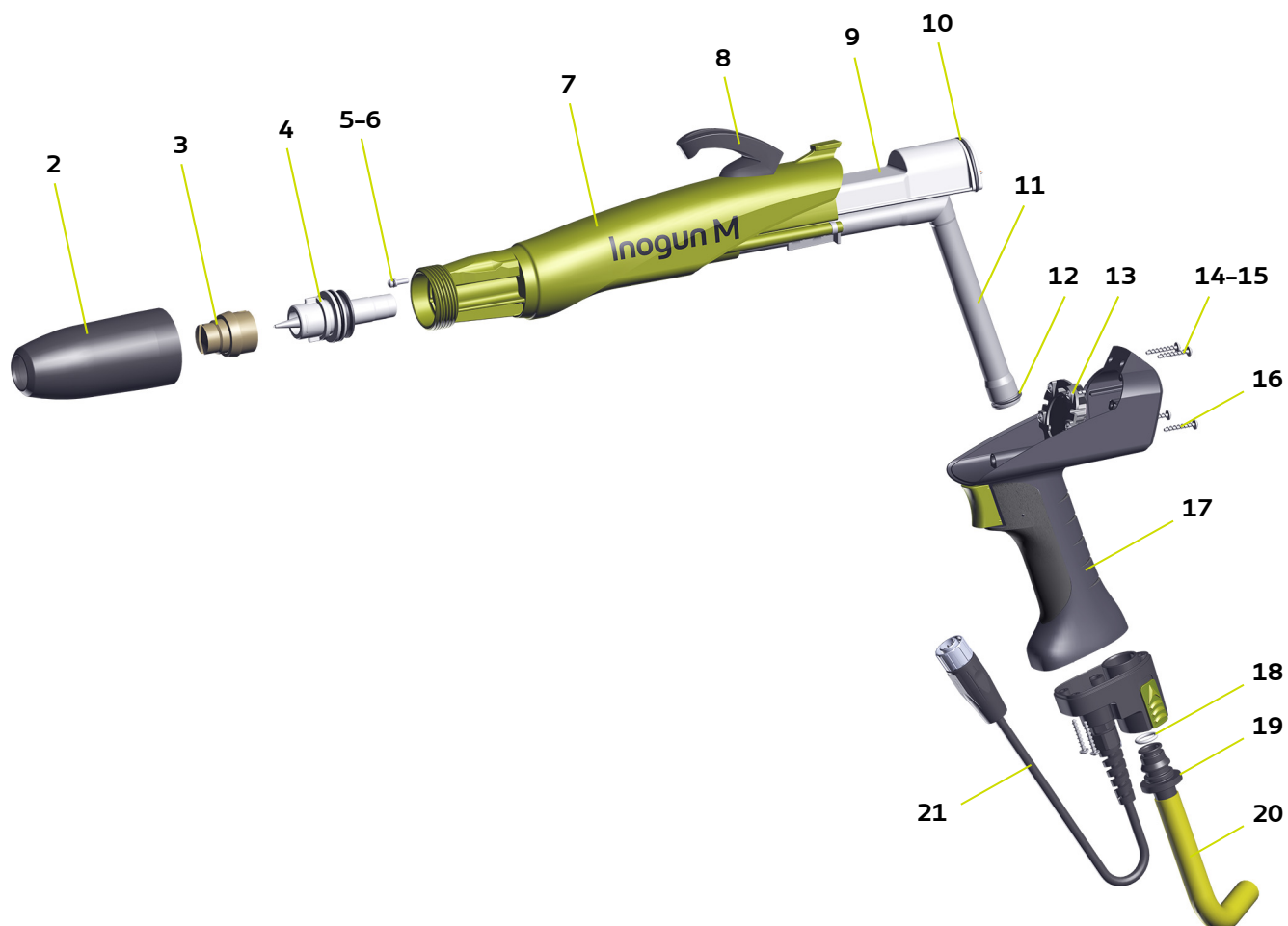

Item	Part Number	Description	Qty	Unit of sale	Maintenance level for spare parts (*)
	910030034	Equipped Inogun M gun (with cable length: 6 m)	1	1	-
	910030034-12	Equipped Inogun M gun (with cable length: 12 m)	1	1	-
	910030034-18	Equipped Inogun M gun (with cable length: 18 m)	1	1	-
2	900018342	Nozzle nut	1	1	-
3	900016321	Medium flat spray deflector (see § 8.4.1 page 46)	1	1	1
4	910027640	Flat spray electrode support (see § 8.4.1 page 46)	1	1	1
5	910028157	HV contact with o-ring	1	1	1
6	J2FTDF027	O-ring (included in item 5)	1	1	1-2
7	910029992	Barrel assembly (see § 8.2 page 44)	1	1	-
8	910029997	Inogun M equipped fixing hook	1	1	-
	X2BDZU003	Screw PT KA 30 X 20 WN 1411	2	1	-
9	910024679	High voltage unit 100kV	1	1	1
10	J2FTCF051	O-ring (included in item 9)	1	1	2
11	910029995	Powder duct	1	1	2
12	J2FTDF177	O-ring (included in item 11)	1	1	1-2
13	910030494	Inogun M control box	1	1	-
14	X2BDVX003	Fan washer AZ3	1	1	-
15	X3GJBP484	Zinc plated screw PT KA30x20 WN1411	5	1	-
	X3BDZU003	Washer Z 3 U zinc-plated steel	5	1	-
16	250000313	Zinc plated screw PT KA30x10 WN1411	6	1	-
17	910029996	Handle assembly (see § 8.3 page 45)	1	1	-
18	J2FTDF153	O-ring (included in item19)	1	1	1-2
19	910029994	Powder connector assembly	1	1	2
20	130001649#	Powder hose POE 11mm green	option	50 m	2
21	910029134	Equipped low voltage cable (lg: 6m)	1	1	-
	910029182	Equipped low voltage cable (lg: 12m)	1	1	-
	910029982	Equipped low voltage cable (lg: 18m)	1	1	-
Not shown					
3	1409259	Round spray deflector, Dia.: 16 mm (white) (see § 8.4.3 page 51)	option	1	1-2
4	910027641	Round spray electrode support (see § 8.4.3 page 51)	option	1	-

(*)

Level 1: 1st emergency parts

Level 2: Wearing parts

8.1.2. Inogun M + spray gun

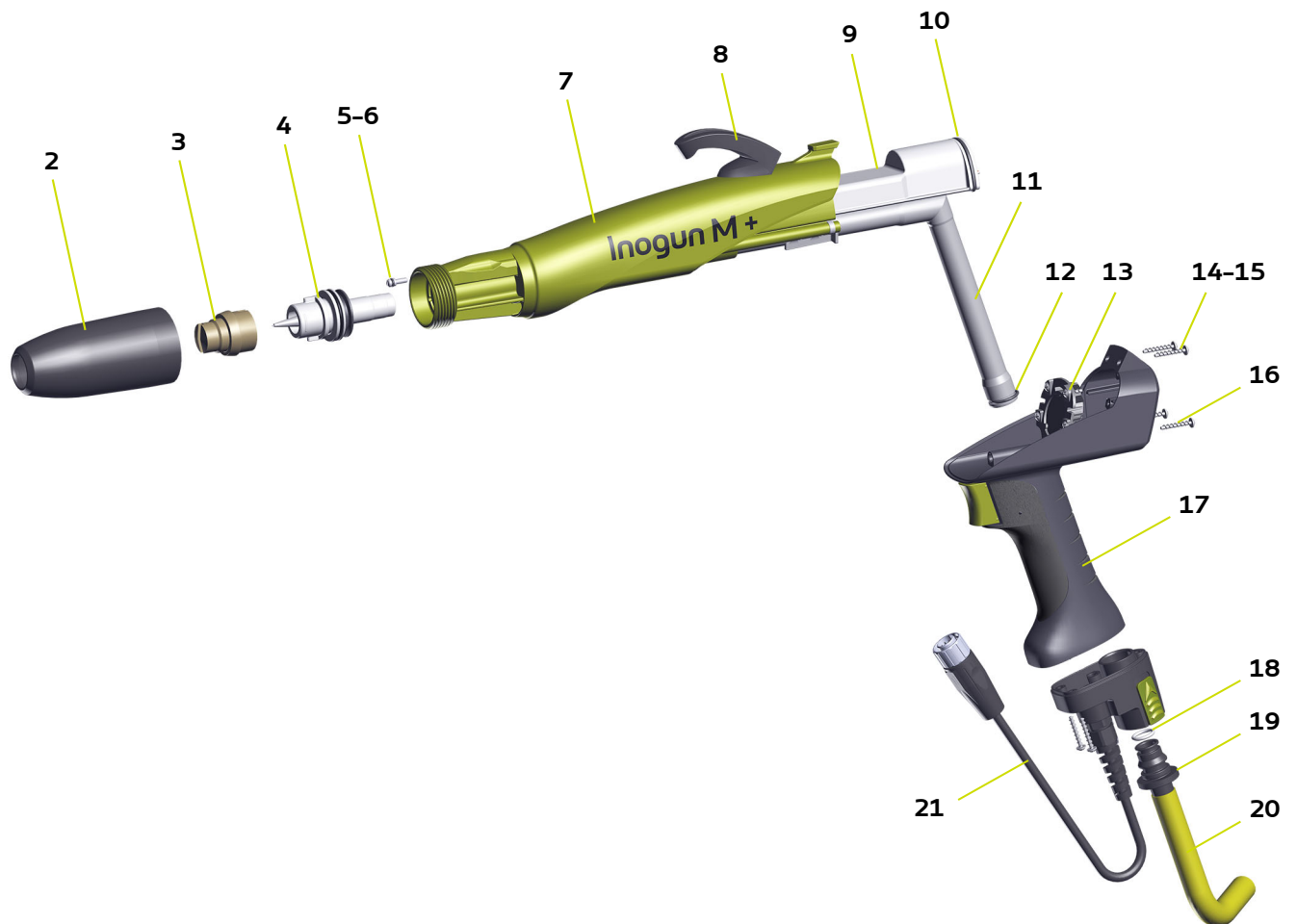

Item	Part Number	Description	Qty	Unit of sale	Maintenance level for spare parts (*)
	910031951	Equipped Inogun M + gun (with cable length: 6 m)	1	1	-
	910031951-12	Equipped Inogun M + gun (with cable length: 12 m)	1	1	-
2	900018342	Nozzle nut	1	1	-
3	900016321	Medium flat spray deflector (see § 8.4.1 page 46)	1	1	1
4	910027640	Flat spray electrode support (see § 8.4.1 page 46)	1	1	1
5	910028157	High voltage contact with o-ring	1	1	1
6	J2FTDF027	O-ring (included in item 5)	1	1	1-2
7	910029992	Barrel assembly (see § 8.2 page 44)	1	1	-
8	910029997	Inogun M equipped fixing hook	1	1	-
	X2BDZU003	Screw PT KA 30 X 20 WN 1411	2	1	-
9	910031489	High voltage unit 100kV	1	1	1
10	J2FTCF051	O-ring (included in item 9)	1	1	2
11	910029995	Powder duct	1	1	2
12	J2FTDF177	O-ring (included in item 11)	1	1	1-2
13	910030494	Inogun M control box	1	1	-
14	X2BDVX003	Fan washer AZ3	1	1	-
15	X3GJBP484	Zinc plated screw PT KA30x20 WN1411	5	1	-
	X3BDZU003	Washer Z 3 U zinc-plated steel	5	1	-
16	250000313	Zinc plated screw PT KA30x10 WN1411	6	1	-
17	910029996	Handle assembly (see § 8.3 page 45)	1	1	-
18	J2FTDF153	O-ring (included in item 19)	1	1	1-2
19	910029994	Powder connector assembly	1	1	2
20	130001649#	Powder hose POE 11mm green	option	50 m	2
21	910029134	Equipped low voltage cable (lg: 6m)	1	1	-
	910029182	Equipped low voltage cable (lg: 12m)	1	1	-
Not shown					
3	1409259	Round spray deflector, Dia.: 16 mm (white) (see § 8.4.3 page 51)	option	1	1-2
4	910027641	Round spray electrode support (see § 8.4.3 page 51)	option	1	-

(*)

Level 1: 1st emergency parts

Level 2: Wearing parts

8.2. Barrel assembly



Item	Part Number	Description	Qty	Unit of sale	Maintenance level for spare parts (*)
7	910029992	Inogun M barrel assembly	1	1	-
	910033168	Inogun M + barrel assembly	1	1	-
7.1	910029993	Air connector assembly	1	1	-
7.2	J2CTPC020	O-ring (included in item 7.1)	4	1	1

(*)

Level 1: 1st emergency parts

Level 2: Wearing parts

8.3. Handle assembly

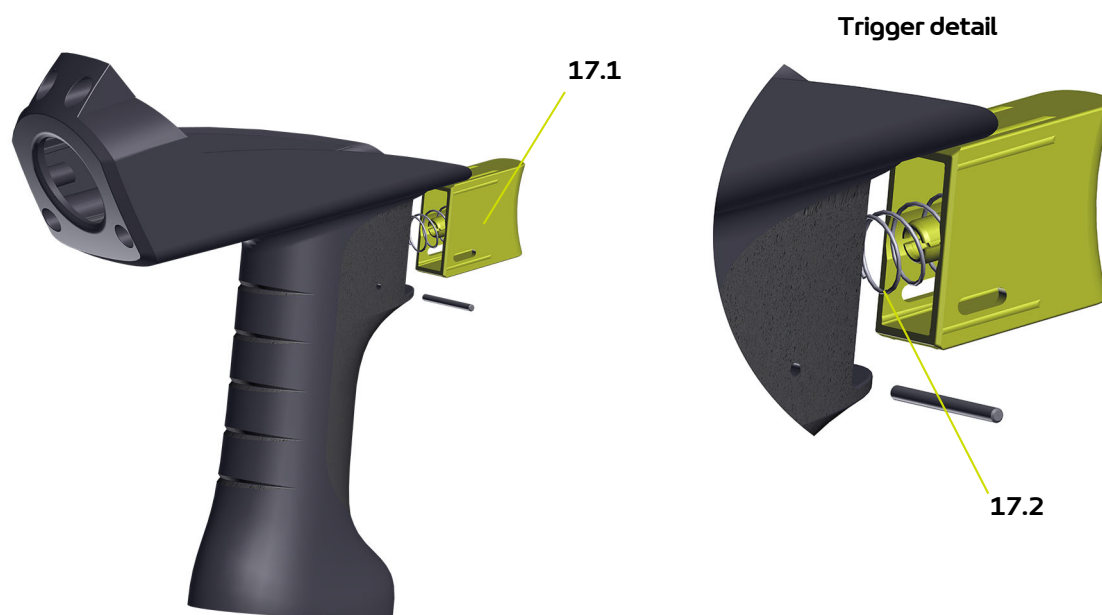

Item	Part Number	Description	Qty	Unit of sale	Maintenance level for spare parts (*)
17	910029996	Handle assembly	1	1	3
17.1	910032827	Trigger assembly	1	1	3
17.2	1408849	Spring of trigger	1	1	3

(*)
Level 1: 1st emergency parts
Level 2: Wearing parts

8.4. Electrode supports

8.4.1. Flat spray

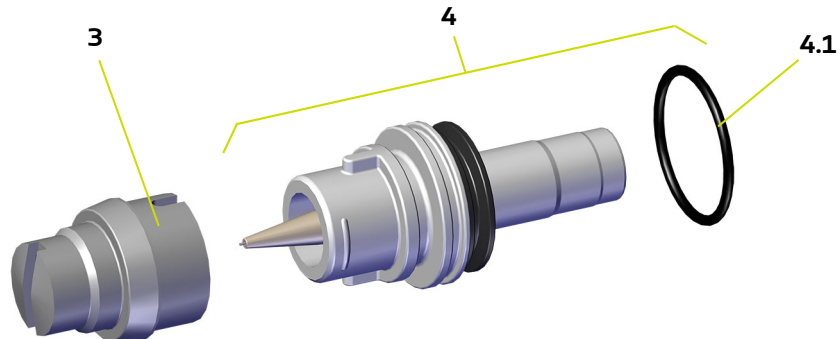

Item	Part Number	Description	Qty	Unit of sale	Maintenance level for spare parts (*)
4	910027640	Flat spray electrode support	1	1	1
4.1	J2CTCN054	O-ring (included in item 4)	1	1	1
3	900016321	Medium flat spray deflector (grey)	1	1	1
	900019952	Narrow flat spray deflector (green)	option	1	1
	900020796	Large flat spray deflector (black)	option	1	1

(*)

Level 1: 1st emergency parts

Level 2: Wearing parts

8.4.2. Optional: Extended flat spray nozzle

Part Number	Nozzle length (mm)	Body	Number of electrode extensions (*)	Nut	Spray deflector	Spring ionizer	Electrode extension	Electrode Support	Reinforcement sleeve
910028485	150	900021080	1						-
910028486	300	900021081	2	900018342	900020896			910027640	-
910032772	450	900021083	3		900021863	900017811	900017797		
910032773	600	900021085	4	900020473	900021864			910032276	900020899

(*) Electrode extension including long electrode extension (900018739), 10 MΩ resistance with spring (910032309) and HV contact extended nozzle (900018741).

8.4.2.1. Lengths 150 and 300 mm

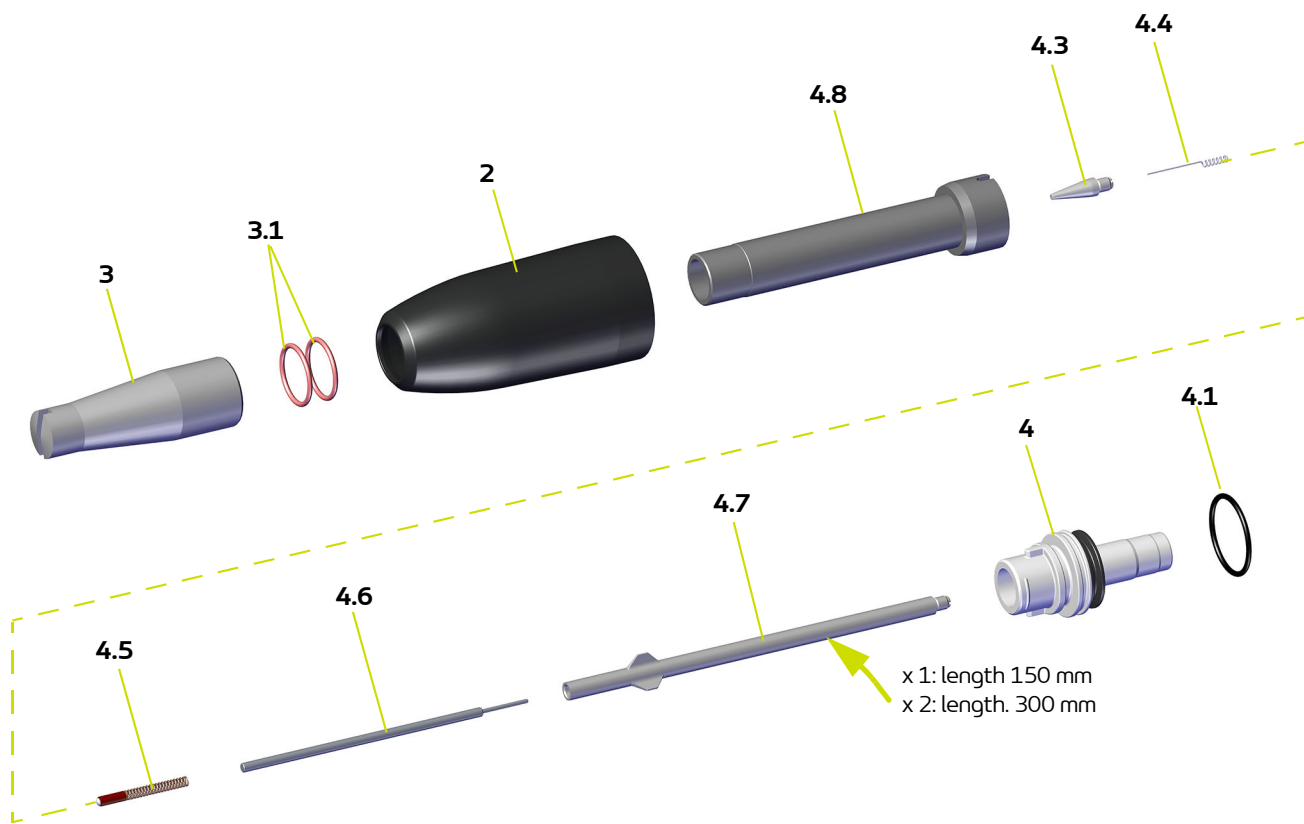

Item	Part Number	Description	Qty	Unit of sale	Maintenance level for spare parts (*)
	910028485	Extended flat spray nozzle length: 150 mm	1	1	-
	910028486	Extended flat spray nozzle length: 300 mm	1	1	-
2	900018342	Extended nozzle nut length: 150 to 300	1	1	-
	900020896	Flat spray narrow deflector for Extended nozzle	1	1	1
3	900021863	Flat spray medium deflector for Extended nozzle	option	1	1-2
	900021864	Flat spray large deflector for Extended nozzle	option	1	1-2
3.1	EU9001917	O-ring	2	1	1-2
4	910027640	Flat spray electrode support length: 150 to 300 mm (see § 8.4.1 page 46)	1	1	1
4.1	J2CTCN054	O-ring (included in item 4)	1	1	1
4.3	900017797	Extension élektrode	1	1	-
4.4	900017811	Ionizer spring	1	1	1
4.5	910032309	Resistance 10 MΩ with spring	1 or 2	1	2
4.6	900018741	HV Contact extended nozzle	1 or 2	1	1-2
4.7	900018739	Long electrode extension	1 or 2	1	-
4.8	900021080	Body length: 150 mm	1	1	-
	900021081	Body length: 300 mm	1	1	-

(*)

Level 1: 1st emergency parts

Level 2: Wearing parts

8.4.2.2. Lengths 450 and 600 mm

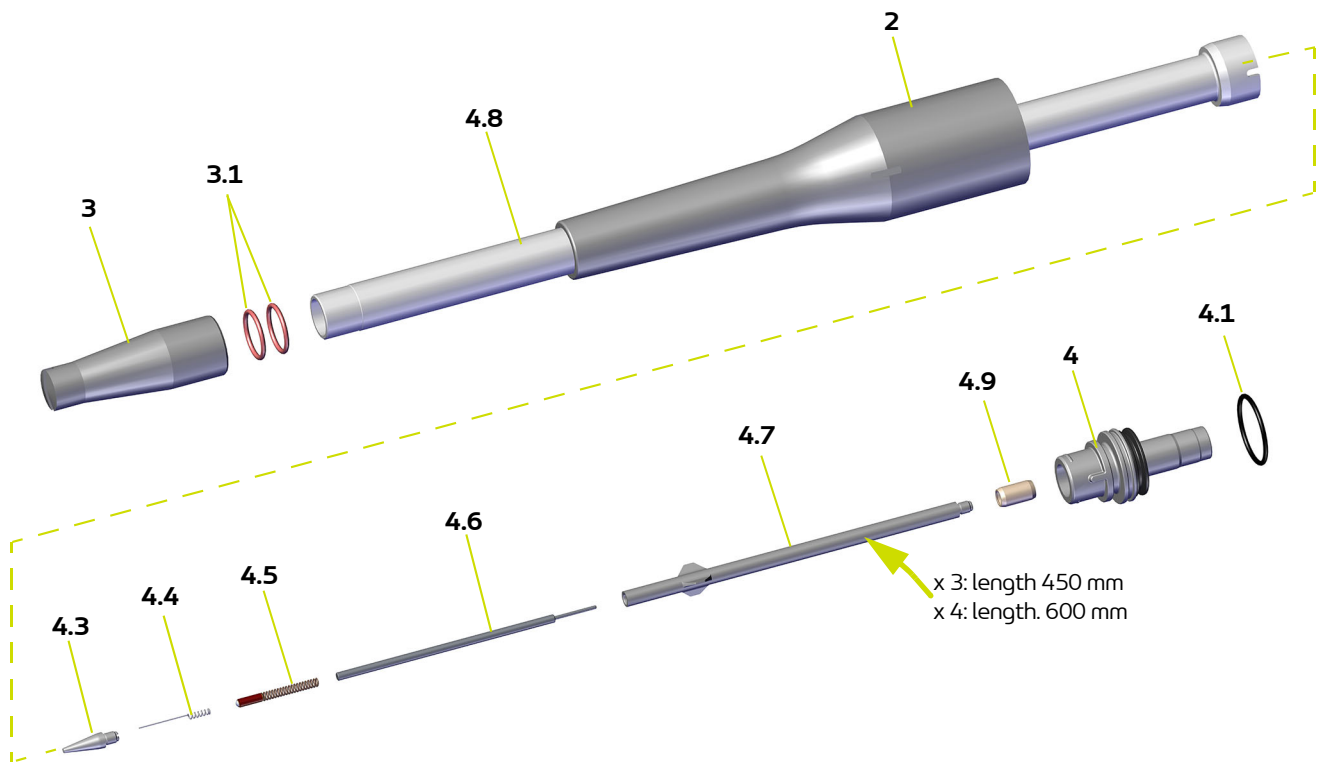

Item	Part Number	Description	Qty	Unit of sale	Maintenance level for spare parts (*)
	910032772	Extended flat spray nozzle length: 450 mm	1	1	-
	910032773	Extended flat spray nozzle length: 600 mm	1	1	-
2	900020473	Extended nozzle nut length: 450 to 600 mm	1	1	-
	900020896	Flat spray narrow deflector for Extended nozzle	1	1	1
3	900021863	Flat spray medium deflector for Extended nozzle	option	1	1-2
	900021864	Flat spray large deflector for Extended nozzle	option	1	1-2
3.1	EU9001917	O-ring	2	1	1-2
4	910032276	Reinforced electrode support length: 450 to 600 mm	1	1	1
4.1	J2CTCN054	O-ring (included in item 4)	1	1	1
4.3	900017797	Extension élektrode	1	1	-
4.4	900017811	Ionizer spring	1	1	1
4.5	910032309	Resistance 10 MΩ with spring	3 or 4	1	2
4.6	900018741	HV Contact extended nozzle	3 or 4	1	1-2
4.7	900018739	Long electrode extension	3 or 4	1	-
4.8	900021083	Body length: 450 mm	1	1	-
	900021085	Body length: 600 mm	1	1	-
4.9	900020899	Reinforcement sleeve (from length: 450) (included in Item 4)	1	1	1

(*)
Level 1: 1st emergency parts
Level 2: Wearing parts

8.4.3. Round spray

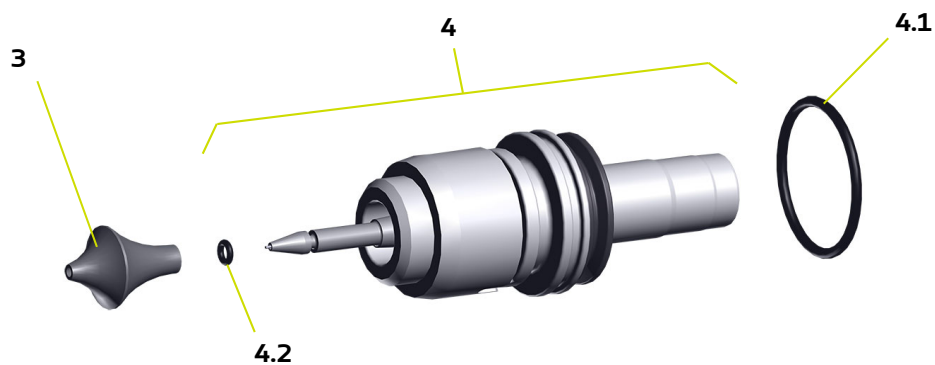

Item	Part Number	Description	Qty	Unit of sale	Maintenance level for spare parts (*)
4	910027641	Round spray electrode support	1	1	1-2
4.1	J2CTCN054	O-ring (included in item 4)	1	1	1-2
4.2	J2CTPC020	O-ring (included in item 4)	1	1	1-2
3	1409259	Round spray deflector, Dia.: 16 mm (white)	1	1	1-2
	900008026	HD Round spray deflector, Dia.: 16 mm (grey)	option	1	1-2
	1411500	Round spray deflector, Dia.: 12 mm (white)	option	1	1-2
	1409260	Round spray deflector, Dia.: 20 mm (white)	option	1	1-2
	900008027	HD Round spray deflector, Dia.: 20 mm (blue)	option	1	1-2
	1411993	Round spray deflector, Dia.: 25 mm (white)	option	1	1-2

(*)
Level 1: 1st emergency parts
Level 2: Wearing parts



The deflectors high durability (HD) are recommended when powder more abrasive is used.

8.4.4. Option, Extended round spray nozzles

Part Number	Nozzle length (mm)	Body	Number of electrode extensions (*)	Nut	Spray déflector	Spring ionizer	Electrode extension	Electrode Support	Reinforcement sleeve
910028576	150	900021080	1	900018342				910027641	-
910028575	300	900021081	2						-
910030942	450	900021083	3	900020473	900020904	900018523	900017552	910032276	900020899
910029099	600	900021085	4						
910031754	1050	900020467	7						
910032347	1500	900021066	10						

(*) Electrode extension including long electrode extension (900018739), 10 MΩ resistance with spring (910032309) and HV contact extended nozzle (900018741).

8.4.4.1. Lengths 150 and 300 mm

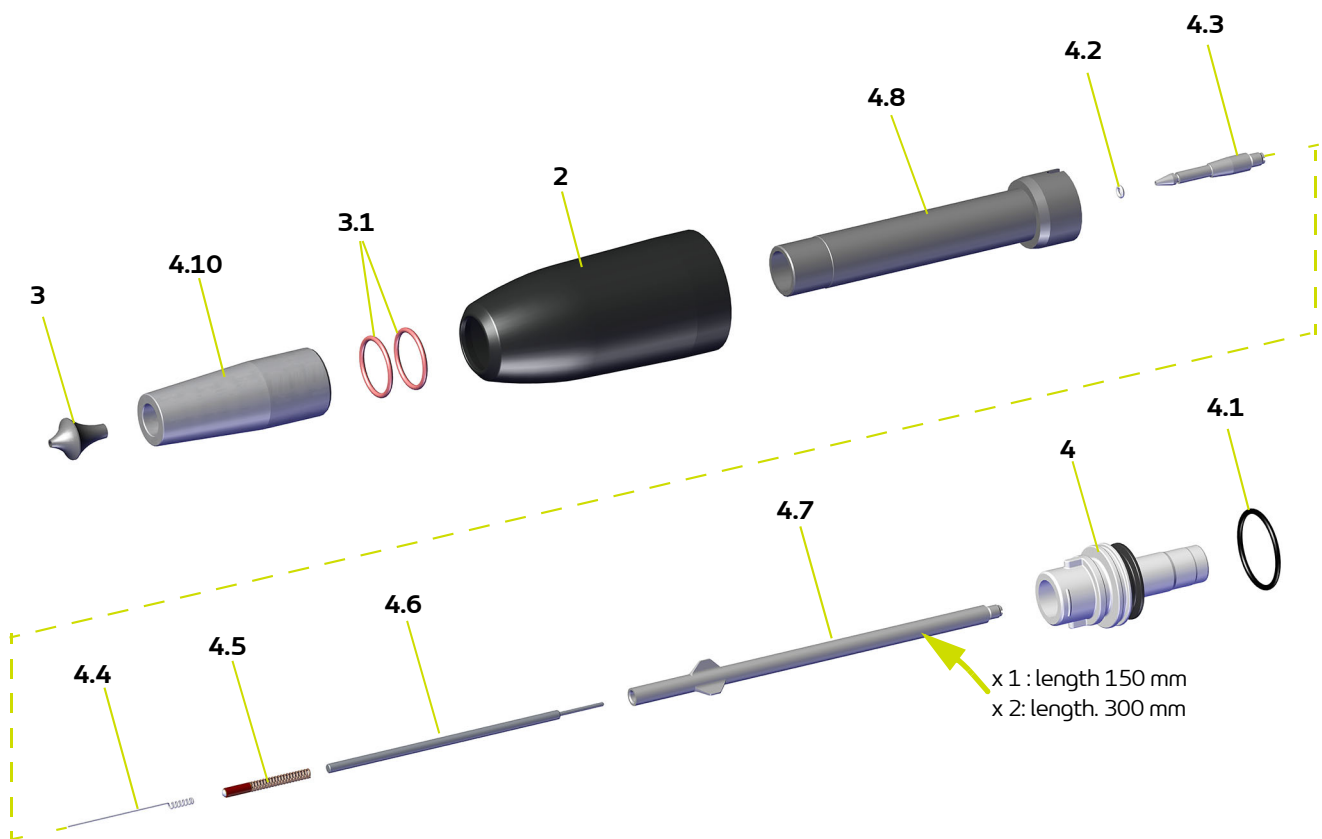

Item	Part Number	Description	Qty	Unit of sale	Maintenance level for spare parts (*)
	910028576	Extended round spray nozzle length: 150 mm	1	1	-
	910028575	Extended round spray nozzle length: 300 mm	1	1	-
2	900018342	Extended nozzle nut length: 150 to 300	1	1	-
3	1409259	Round spray deflector, Dia.: 16 mm (white)	1	1	1-2
	900008026	HD Round spray deflector, Dia.: 16 mm (grey)	option	1	1-2
	1411500	Round spray deflector, Dia.: 12 mm (white)	option	1	1-2
	1409260	Round spray deflector, Dia.: 20 mm (white)	option	1	1-2
	900008027	HD Round spray deflector, Dia.: 20 mm (blue)	option	1	1-2
	1411993	Round spray deflector, Dia.: 25 mm (white)	option	1	1-2
3.1	EU9001917	O-ring	2	1	1-2
4	910027641	Round spray electrode support (see § 8.4.3 page 51)	1	1	1
4.1	J2CTCN054	O-ring (included in item 22)	1	1	1-2
4.2	J2CTPC020	O-ring (included in item 22)	1	1	1-2
4.3	900017552	Electrode extension	1	1	-
4.4	900018523	Ionizer spring	1	1	1
4.5	910032309	Resistance 10 MΩ with spring	1 ou 2	1	1
4.6	900018741	HV Contact extended nozzle	1 ou 2	1	1-2
4.7	900018739	Long electrode extension	1 ou 2	1	-
4.8	900021080	Body length: 150 mm	1	1	-
	900021081	Body length: 300 mm	1	1	-
4.10	900020904	Extended nozzle round spray deflector	1	1	1-2

(*)

Level 1: 1st emergency parts

Level 2: Wearing parts

8.4.4.2. Lengths from 450 to 1500 mm

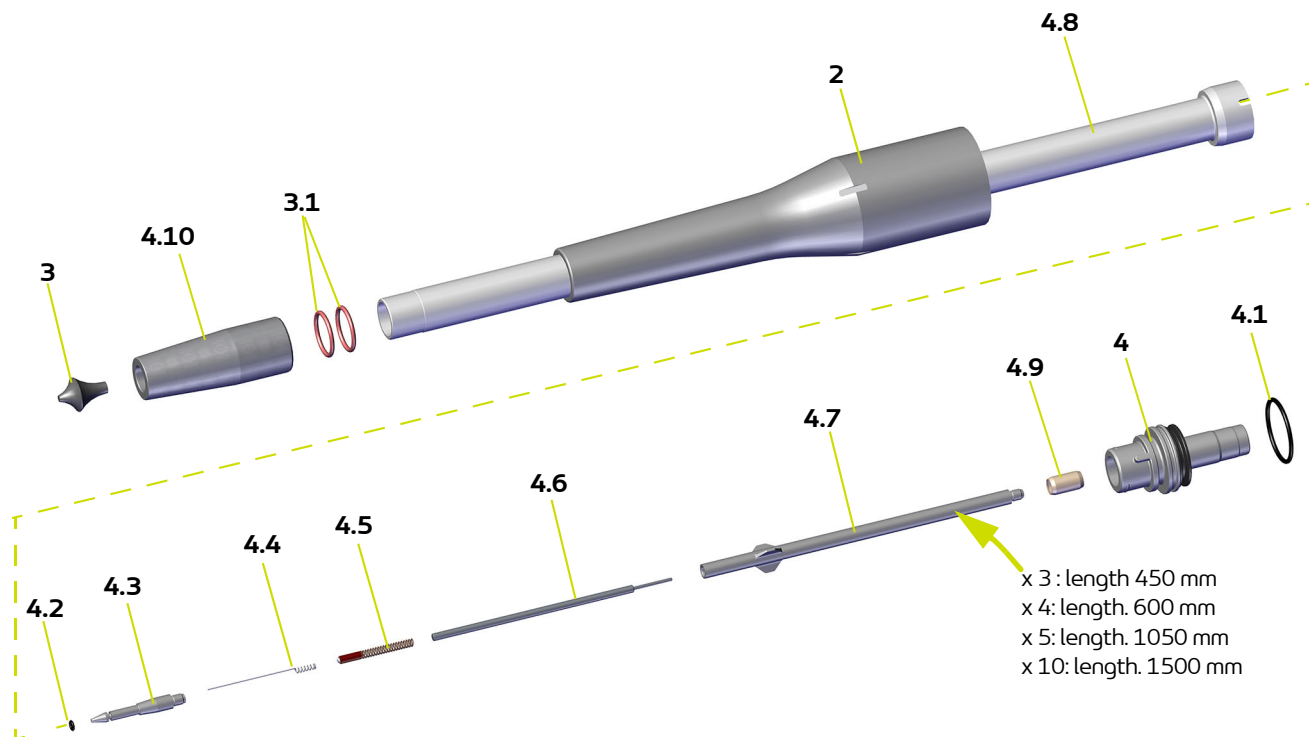

Item	Part Number	Description	Qty	Unit of sale	Maintenance level for spare parts (*)
	910030942	Extended round spray nozzle length: 450 mm	1	1	-
	910029099	Extended round spray nozzle length: 600 mm	1	1	-
	910031754	Extended round spray nozzle length: 1050 mm	1	1	-
	910032347	Extended round spray nozzle length: 1500 mm	1	1	-
2	900020473	Extended nozzle nut length: 450 to 600	1	1	-
3	1409259	Round spray deflector, Dia.: 16 mm (white)	1	1	1-2
	900008026	HD Round spray deflector, Dia.: 16 mm (grey)	option	1	1-2
	1411500	Round spray deflector, Dia.: 12 mm (white)	option	1	1-2
	1409260	Round spray deflector, Dia.: 20 mm (white)	option	1	1-2
	900008027	HD Round spray deflector, Dia.: 20 mm (blue)	option	1	1-2
	1411993	Round spray deflector, Dia.: 25 mm (white)	option	1	1-2
3.1	EU9001917	O-ring	2	1	1-2
4	910032276	Reinforced electrode support length: 450 to 600 mm	1	1	1
4.1	J2CTCN054	O-ring (included in item.4)	1	1	1
4.2	J2CTPC020	O-ring (included in item.4)	1	1	1-2
4.3	900017552	Electrode extension	1	1	-
4.4	900018523	Ressort ioniseur	1	1	1
4.5	910032309	Resistance 10 MΩ with spring	X	1	1
4.6	900018741	HV Contact extended nozzle	X	1	1-2
4.7	900018739	Long electrode extension	X	1	-
4.8	900021083	Body length: 450 mm	1	1	-
	900021085	Body length: 600 mm	1	1	-
	900020467	Body length: 1050 mm	1	1	-
	900021066	Body length: 1500 mm	1	1	-
4.9	900020899	Reinforcement sleeve (from length: 450) (included in item. 4)	1	1	1
4.10	900020904	Extended nozzle round spray deflector	1	1	1-2

(*)

Level 1: 1st emergency parts

Level 2: Wearing parts

8.5. Counter-electrode assembly

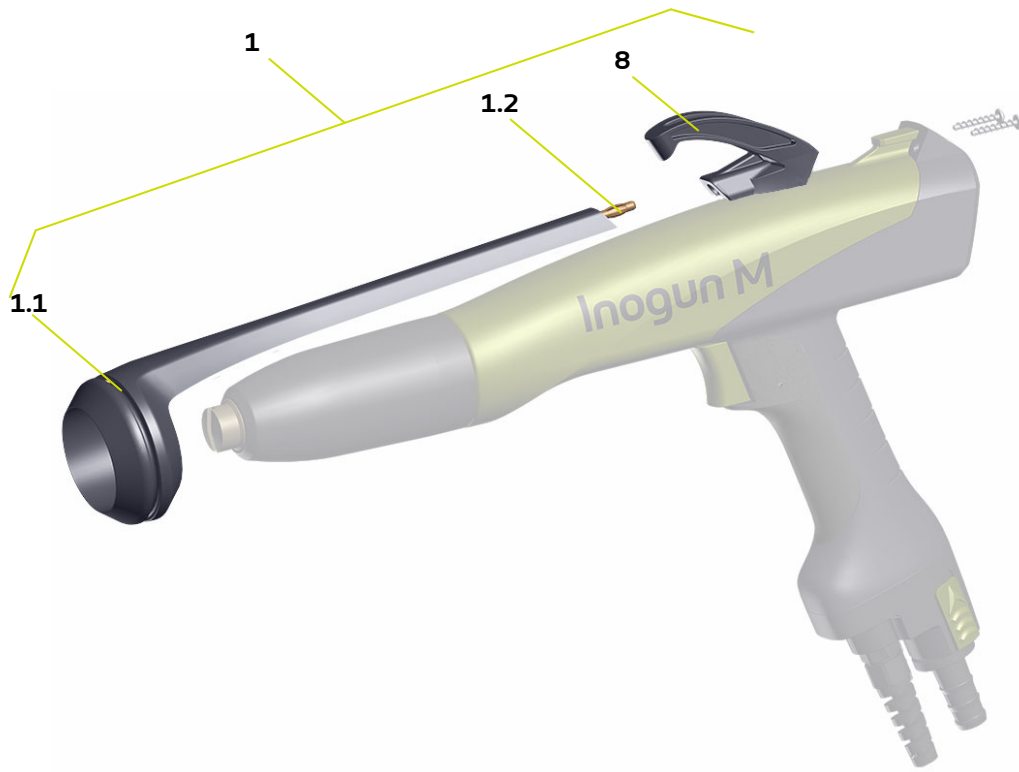

Item	Part Number	Description	Qty	Unit of sale	Maintenance level for spare parts (*)
1	910031755	Counter-electrode assembly	1	1	-
1.1	J3ETOR097	O-ring (included in item 1)	1	1	1-2
1.2	110001096	Banana plug Dia:4 (included in item 1)	1	1	1
8	900021017	Conductive hook	1	1	-

(*)
Level 1: 1st emergency parts
Level 2: Wearing parts

8.6. Spray type conversion kits for extended nozzles

8.6.1. Kit for converting a flat spray into a round spray for extended nozzles

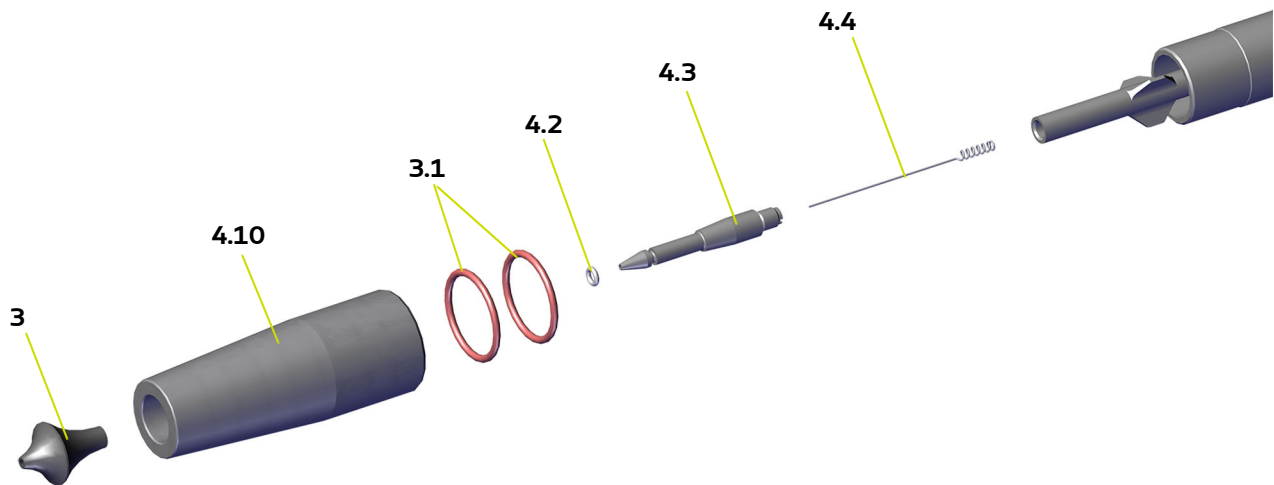

Item	Part Number	Description	Qty	Unit of sale	Maintenance level for spare parts (*)
22	910032710	Kit for converting a flat spray into a round spray for extended nozzles	1	1	-
3	1409259	Round spray deflector Dia: 16 mm (white)	1	1	1-2
3.1	900020904	Extended nozzle round spray deflector	1	1	-
4.2	EU9001917	O-ring	2	1	1-2
4.3	J2CTPC020	O-ring	1	1	1-2
4.4	900017552	Round spray electrode extension	1	1	-
4.10	900018523	Round spray ionizer spring	1	1	1

(*)

Level 1: 1st emergency parts

Level 2: Wearing parts

8.6.2. Kit for converting a round spray into a flat spray for extended nozzles

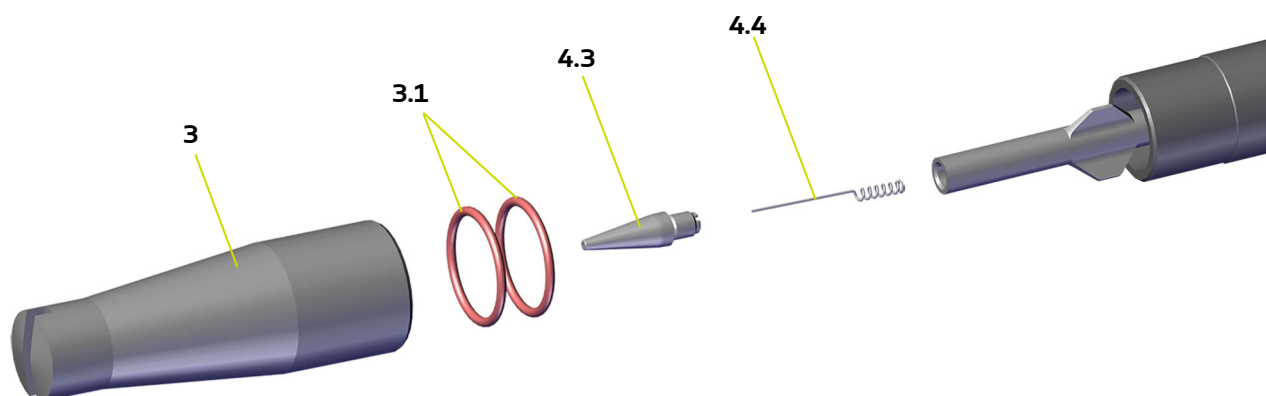

Item	Part Number	Description	Qty	Unit of sale	Maintenance level for spare parts (*)
23	910032709	Kit for converting a round jet into a flat spray for extended nozzles	1	1	-
3	900020896	Flat spray narrow deflector for Extended nozzle	1	1	1-2
3.1	EU9001917	O-ring	2	1	1-2
4.3	900017797	Flat spray electrode extension	1	1	-
4.4	900017811	Flat spray ionizer spring	1	1	1
Option					
3	900021863	Flat spray medium deflector for Extended nozzle	option	1	1-2
	900021864	Flat spray large deflector for Extended nozzle	option	1	1-2

(*)
Level 1: 1st emergency parts
Level 2: Wearing parts

8.7. Additional equipment

Manual flush filter

Part Number	Description	Qty	Unit of sale	Maintenance level for spare parts (*)
160000148	5µm air filter	1	1	1 - 2
F6RLCS204	Male union	2	1	-
X3AVSY119	Screw Chc M4 x12 steel 8/8 zinc plated	2	1	-
X2BDMU004	Washer M4 U zinc plated steel	2	1	-

(*)

Level 1: 1st emergency parts

Level 2: Wearing parts

9. Revision index History

Created by		Checked by: E. Ghio		Approved by S. Court	
Date	By:	Index	Purpose of the modification and location		
07/2020	S. Court	A	First issue		
09/2020	S. Court	B	Addition of the dual control of the gun, modification of the tightening torques, addition of spare parts o-rings, modification of illustrations and modification of the filter part number.	§ 2, 5, 7 and 9	
07/2021	O. Aubin	C	Add: - CSA certification, - Inogun M + gun version , - extended nozzles, - wire guide for HV cascade - counter électrode - spray type conversion kits - P/N of equipped trigger	§ 1, 3.2, 7.3.3, 9.1, 9.2, 9.3, 9.4, 9.5and 9.6	
09/2022	O. Aubin	D	UKCA and QPS Marking Transfer of CSA certification to QPS Change of identity and logo Update of the graphic charter Add medium and large deflectors	§ 8.4.2 and 8.4.6	

10. Appendices

10.1. Preventive maintenance plan

PLAN DE MAINTENANCE PREVENTIVE / PREVENTIVE MAINTENANCE PLAN

Numéro d'ordre Serial	Ensemble - Assembly	Sous ensemble Sub assembly	Désignation de l'élément Designation of the assembly	Pour 1 ensemble - For 1 assembly			Acteurs Métiers Operators - skill (3)				Niveau Level (4)		Manuel d'utilisation Instruction manual	Outil Tool	Commentaires Notes	
				Action à effectuer Action to carry out	Temps prévu Estimated Time (1)		Périodicité Periodicity (H / hour) (2)	M	F	E	A	1				2
					100eme H	mn										
Avant toute intervention, se référer au chapitre sécurité du manuel de l'équipement / Before any intervention, see chapter safety equipment manual																
1	Inogun M Pistolet poudre Inogun M Spray gun	Équipement Equipment	Tuyaux et raccords poudre Hoses and unions powder	Contrôle usure / fuite Wear / Leakage check	1,66	1	8	X				1			A chaque début de production Every start production	
2		Équipement Equipment	Tuyaux et raccords pneumatique Hoses and unions	Contrôle usure / fuite Wear / Leakage check	1,66	1	8	X				1			A chaque début de production Every start production	
3		Équipement Equipment	Boîtier de commande arrière Rear control box	Vérification état et fonctionnalité Checking status and functionality	1,66	1	8	X				1			A chaque début de production Every start production	
4		Équipement Equipment	Gachette Trigger	Vérification état et fonctionnalité Checking status and functionality	1,66	1	8	X				1			A chaque début de production Every start production	
5		Équipement Equipment	Projecteur, buse, électrode et conduit poudre Projector, nozzle, electrode and powder pipe	Nettoyage avec air comprimé Cleaning with compressed air	8,33	5	8	X				1			A chaque arrêt de production - Pression maxi 2,5 bars Every break time - Air pressure max 2,5Bars	
6		Équipement Equipment	Buse et déflecteur Spray-gun nozzle and deflector	Nettoyage Cleaning	8,33	5	40	X				1			Solvant MIBK (Méthyle Isobutyl Cétone) Solvent MIBK (Methyl Isobutyl Ketone)	
7		Équipement Equipment	Support électrode Electrode support	Vérification encrassement électrode Checking for electrode contamination	1,66	1	40	X				1				
8		Équipement Equipment	Support électrode Electrode support	Vérification joint conducteur Checking conductive O-ring	1,66	1	40	X				1				

PLAN DE MAINTENANCE PREVENTIVE / PREVENTIVE MAINTENANCE PLAN

Numéro d'ordre Serial	Ensemble - Assembly	Sous ensemble Sub assembly	Désignation de l'élément Designation of the assembly	Pour 1 ensemble - For 1 assembly			Acteurs Métiers Operators - skill (3)				Niveau Level (4)		Manuel d'utilisation Instruction manual	Outil Tool	Commentaires Notes	
				Action à effectuer Action to carry out	Temps prévu Estimated Time (1)		Périodicité Periodicity (H / hour) (2)	M	F	E	A	1				2
					100eme H	mn										
9		Équipement Equipment	Contact HT canon HV contact barrel	Vérification propreté contact Checking contact cleanliness	1,66	1	40	X				1				
10		Équipement Equipment	Contact Barrel	Vérification orifice sortie air de soufflage électrode Checking the cleanliness of the blowing air outlet electrode	1,66	1	40	X				1				
11		Équipement Equipment	Coude poudre Elbow powder	Vérification état d'usure et encrassement Checking the state of wear and soiling	1,66	1	500 (4 fois/an)	X				2	(DRT7132)	Tournevis empreinte Philips PH1 Philips screwdriver PH1	Remplacement si nécessaire Replace if it is required	
12		Équipement Equipment	Câblage Wiring	Vérification hygiène connectique Checking wiring	1,66	1	1000 (2 fois/an)			X		2				
13		Paramètre process Process parameter	Unité haute tension High voltage unit	Essais Haute tension High voltage test	3,33	2	1000 (2 fois/an)			X		2				
14		Projecteur Spray gun	Fixations Fixations	Vérification fixation appareil Checking fixing projector	3,33	2	1000 (2 fois/an)	X				2				
15		Équipement Equipment	Coude poudre Elbow powder	Remplacement Replacement	16,66	10		X				2	(DRT7132)	Tournevis empreinte Philips PH1 Philips screwdriver PH1		
16	(DRT7132)	Projecteur Spray gun	Buse Spray gun nozzle	Vérification pulvérisation poudre Checking spray	1,66	1		X				1 2			Durant la production During production	
17	Pièces de rechange Spare parts	Stock Stock	Pièces Spare parts	Vérification disponibilité des pièces de première urgence Checking availability of spare parts	8,33	5	2 fois/an	X	X			1 2				

10.2. EU and UK declarations of conformity



UE DECLARATION OF CONFORMITY

(1) The manufacturer herewith declares that the equipment is in conformity with the relevant Union harmonization legislation.

(2) Equipment type	PULVERISATEUR ELECTROSTATIQUE DE PEINTURE POWDRE / ELECTROSTATIC POWDER PAINT SPRAY SYSTEM			
	Inogun M ou/ or Inogun M+ avec/ with Inobox ou/ or Inocontroller			
(3) Applicable Directives	2014/34/UE ATEX Directive	(4) Markings	Sprayer Inogun M / M+ : II 2 D 2 mJ	
			Control module Inobox : II 3 (2) D [2 mJ] Matériel associé Inobox peut être installé en zone 22 Associated equipment Inobox can be installed in zone 22	
			Control module Inocontroller : II (2) D [2 mJ] Matériel associé Inocontroller doit être installé en zone sûre (zone non dangereuse) Associated equipment Inocontroller must be installed in safe zone (non explosive area)	
		(5) Harmonised standards	EN 50177 : 2009 / A1 : 2013 EN 50050-2 : 2013	EN 60079-0 : 2018 EN 60079-31 : 2014
		(6) Conformity assessment procedures	UE type examination certificate : INERIS 19ATEX0021X	Notified Body : INERIS 0080 60550 Verneuil-en-Halatte France
<p>Le signe X placé derrière le numéro d'attestation d'examen UE de type indique que cet appareil est soumis à des conditions spéciales d'utilisation: cet appareil est prévu pour une gamme de températures ambiantes de 0°C à 40°C. Lors de l'installation, l'utilisateur devra tenir compte du fait que le clavier du module de commande Inobox n'a subi qu'un choc mécanique faible (groupe II suivant EN 60079-0). Le module de commande Inobox doit être protégé de la lumière.</p> <p>The X sign placed after the EU type examination certificate number indicates that this equipment is intended for an ambient temperature range of 0°C to 40°C. During the installation, the user will take into consideration that the keypad underwent only a shock corresponding to an energy of a low risk (Group II according to EN 60079-0), and must be protected against the high mechanical hazard risk. The Inobox has to be protected from light.</p>				
2014/30/UE Electromagnetic Compatibility Directive	(5) Harmonised standards	Inocontroller + Inogun A : EN 61000-6-4 : 2007 /A1 : 2011 EN 61000-6-2 : 2005	Inobox + Inogun M : EN 61326-1 : 2013 EN 50663 : 2017 EN 62479 : 2010	
2014/35/UE Low Voltage Directive	(5) Harmonised standards	EN 61010-1 : 2011		
(7) This declaration of conformity is issued under the sole responsibility of the manufacturer.				

Director of the MEYLAN site - Executive Management (EM)

Richard WLODARCZYK

DocuSigned by:

Richard Wlodarczyk

9900D9C0034B4A2...

Established in Meylan, on 16-janv.-23 | 09:25 CET

SAMES

Siège Social / Headquarter: 13, chemin de Malacher - CS70086 - 38243 Meylan Cedex - France - Tél / Phone: +33 (0)4 76 41 60 60
SAS au capital de 12.720.000 euros | RCS Grenoble: 572 051 688 | Code APE: 2829B | TVA intracom: FR36 572051688
info@sames.com - www.sames.com | Société d'EXEL Industries / EXEL Industries company



UE DECLARATION OF CONFORMITY

(1)	<p>Le Fabricant déclare que le matériel désigné ci-après est conforme à la législation d'harmonisation de l'Union applicable suivante/ Der Hersteller erklärt, dass das nachfolgend bezeichnete Material den folgenden anwendbaren Harmonisierungsrechtsvorschriften der Union entspricht / El fabricante declara que el equipo designado a continuación es conforme con la siguiente legislación de armonización de la UE aplicable / Il fabbricante dichiara che l'attrezzatura designata di seguito è conforme alla seguente legislazione di armonizzazione UE applicabile / O Fabricante declara que o equipamento designado abaixo está em conformidade com a seguinte legislação de harmonização aplicável da UE / Producent deklaruje, że urządzenie wskazane poniżej jest zgodne z następującymi obowiązującymi przepisami harmonizacyjnymi UE/ De fabrikant verklaart dat de hieronder beschreven apparatuur in overeenstemming is met de volgende toepasselijke EU-harmonisatiewetgeving/ Výrobce prohlašuje, že níže uvedené zařízení je ve shodě s těmito platnými harmonizačními právními předpisy EU/ Výrobce prohlašuje, že níže uvedené zařízení je ve shodě s těmito platnými harmonizačními právními předpisy EU/ Producenten erklærer, at det nedenfor angivne udstyr er i overensstemmelse med følgende gældende EU-harmoniseringslovgivning/ Valmistaja vakuuttaa, että jäljempänä mainitut laitteet ovat seuraavien sovellettävien EU:n yhdenmukaistamislainsäädännön mukaisia./ Tootja kinnitab, et allpool nimetatud seadmed vastavad järgmistele kohaldatavatele ELi ühtlustamise õigusaktidele./ Ražotājs apliecina, ka turpmāk norādītās iekārtas atbilst šādiem piemērojamiem ES saskaņošanas tiesību aktiem./ Gamintojas pareiškia, kad toliau nurodyta įranga atitinka šiuos taikytinus ES derinamuosius teisės aktus/ Производителят декларира, че посоченото по-долу оборудване е в съответствие със следното приложимо законодателство на ЕС за хармонизация/ A gyártó kijelenti, hogy az alább megjelölt berendezés megfelel a következő alkalmazandó uniós harmonizációs jogszabályoknak / Producătorul declară că echipamentul desemnat mai jos este în conformitate cu următoarea legislație de armonizare a UE aplicabilă/ Ο κατασκευαστής δηλώνει ότι ο εξοπλισμός που αναφέρεται κατωτέρω συμμορφώνεται με την ακόλουθη ισχύουσα νομοθεσία ενωρίμωσης της ΕΕ/ Προϊζνοδαč ovime izjavljuje da je oprema u skladu sa zakonskim zahtjevima Uje dinjene Kraljevine./ Výrobca vyhlasuje, že nižšie uvedené zariadenie je v súlade s týmito platnými harmonizačnými právnymi predpismi EÚ/ Произвојалец изјављује, да је сподат наведена опрема складна з насљедној вељавној усклађевалној законоданој ЕУ/ Производител заявяет, что указанное ниже оборудование соответствует следующим применимым законодательным актам ЕС по гармонизации/ 製造者は、以下に指定された装置が、適用される以下のEU調和法に適合していることを宣言する。/ 製造商声明, 下面指定的设备符合以下适用的欧盟协调立法。</p>
(2)	<p>Type d'équipement/ Art der Ausrüstung/ Tipo de equipo/ Tipo di attrezzatura/ Tipo de equipamento/ Rodzaj sprzętu/ Type uitrusting/ Typ zařízení/ Typ av anordning/ Type af anordning/ Laitteen tyyppi/ Seadme tüüp/ Iekārtas tips/ Įrangos tipas/ Вид оборудоване/ A berendezés típusa/ Tipul de echipament/ Τύπος εξοπλισμού/ Vrsta opreme/ Typ zariadenia/ Vrsta naprave/ Тип оборудованя/ 機器の種類/ 设备类型</p>
(3)	<p>Directives applicables/Anwendbare Richtlinien/Directivas aplicables/Direttive applicabili/Diretivas aplicáveis/Obowiązujące dyrektywy/Toepasselijke richtlijnen/Platné smernice/Tillämpliga direktiv/Gældende direktiver/Sovellettavat direktiivit/Kohaldatavad direktiivid/Piemērojamās direktīvas/Taikomos direktivos/Приложими директиви/Alkalmazandó irányelvek/Directive aplicabile/ισχύουσες οδηγίες/Primjenjive smjernice/Uplatnitelné smernice/Veljavne directive/Применимые директивы/適用される指令/适用的指令</p>
(4)	<p>Marquage/Markierung/Marcado/Marcatura/Marcação/Znakowanie/Markering/Označení/Märkning/Mærkning/Merkintä/Märgistus/Markējums/Ženkinimas/Маркировка/Jelðis/Marcare/Σήμανση/Obilježava/Označovanie /Označevanje/Маркировка/マーキング/标识</p>
(5)	<p>Normes harmonisées/Harmonisierte Normen / Normas armonizadas/ Norme armonizate/Normas harmonizadas /Normy zharmonizowane/Geharmoniseerde normen /Harmonizované normy /Harmoniserade standarder /Harmoniserede standarder /Yhdenmukaistetut standardit /Harmoniseeritud standardid /Saskaņotie standarti /Suderintii standartai /Хармонизирани стандарти /Harmonizált szabványok / Standarde armonizate/ Evarmonizimëna prototipa /Harmonizirani standardi /Harmonizované normy /Usklajeni standardi /Гармонизированные стандарты /整合規格 /协调标准</p>
(6)	<p>Procédure d'évaluation de la conformité/Verfahren der Konformitätsbewertung/Procedimiento de evaluación de la conformidad/Procedura di valutazione della conformità/Procedimento de avaliação da conformidade/Procedura oceny zgodności/Conformiteitsbeoordelingsprocedure/Postup posuzování shody / Förfarande för bedömning av överensstämmelse/Procedure for overensstemmelsesvurdering /Vaatimustenmukaisuuden arviointimenettely / Vastavushindamismenetlus/Atbilstības novērtēšanas procedūra /Atitikties vertinimo procedūra /Процедура за оценка на съответствието /Megfelelőségértékelési eljárás / Procedura de evaluare a conformității/Διαδικασία αξιολόγησης της συμμόρφωσης /Postupak ocjene uskladnosti /Postup posudzovanja zhody /Postopek ugotavljanja skladnosti /Процедура оценки соответствия / 適合性評價手順 / 符合性評估程序</p>
(7)	<p>Cette déclaration de conformité est délivrée sous la seule responsabilité du fabricant. / Diese Konformitätserklärung wird unter der alleinigen Verantwortung des Herstellers ausgestellt./ Esta declaración de conformidad se emite bajo la única responsabilidad del fabricante./ Questa dichiarazione di conformità è rilasciata sotto la sola responsabilità del produttore./ Esta declaração de conformidade é emitida sob a exclusiva responsabilidade do fabricante./ Niniejsza deklaracja zgodności została wydana na wyłączną odpowiedzialność producenta./ Deze verklaring van overeenstemming wordt afgegeven onder de uitsluitende verantwoordelijkheid van de fabrikant./ Toto prohlášení o shodě je vydáno na výhradní odpovědnost výrobce./ Denna försäkran om överensstämmelse utfärdas på tillverkarens eget ansvar. / Denne overensstemmelseserklæring er udstedt på producentens eget ansvar./ Tämä vaatimustenmukaisuusvakuutus annetaan valmistajan yksinomaisella vastuulla./ Käesolev vastavusdeklaratsioon on välja antud tootja ainuvastutusel./ Šī atbilstības deklarācija ir izdota uz ražotāja atbildību./ Už šia atitikties deklaraciją atsako tik gamintojas./ Настоящата декларация за съответствие се издава на пълната отговорност на производителя./ Ezt a megfelelőségi nyilatkozatot a gyártó kizárólagos felelősége mellett adjuk ki./ Prezenta declarație de conformitate este emisă pe răspunderea exclusivă a producătorului./ Η παρούσα δήλωση συμμόρφωσης εκδίδεται με αποκλειστική ευθύνη του κατασκευαστή./ Ova izjava o skladnosti izdaje se isključivo pod odgovornošću proizvođača./ Toto vyhlásenie o zhode sa vydáva na výhradnú zodpovednosť výrobcu./ Za to izjavo o skladnosti je odgovoren izključno proizvajalec./ Din iddikjarazzjoni ta' konformità għandha tinfhaq taht ir-responsabbiltà unika tal-manifattur./ Данная декларация соответствия выдана под исключительную ответственность производителя./ この適合宣言は、製造者の単独責任のもとで発行されています。/本符合性声明由制造商全权负责发布。</p>

SAMES

Siège Social / Headquarter: 13, chemin de Malcher - CS70086 - 38243 Meylan Cedex - France - Tél / Phone: +33 (0)4 76 41 60 60
 SAS au capital de 12.720.000 euros | RCS Grenoble: 572 051 688 | Code APE: 2829B | TVA intracom: FR36 572051688
info@sames.com - www.sames.com | Société d'EXEL Industries / EXEL Industries company



UK DECLARATION OF CONFORMITY

(1) The manufacturer herewith declares that the equipment is in conformity with the relevant Union harmonization legislation.

(2) Equipment type	PULVERISATEUR ELECTROSTATIQUE DE PEINTURE POUDRE / ELECTROSTATIC POWDER PAINT SPRAY SYSTEM			
	Inogun M ou/ or Inogun M+ avec/ with Inobox ou/ or Inocontroller			
(3) Applicable Directives	2016 No. 1107	(4) Markings	Sprayer Inogun M / M+ : II 2 D 2 mJ	
			Control module Inobox : II 3 (2) D [2 mJ] Matériel associé Inobox peut être installé en zone 22 Associated equipment Inobox can be installed in zone 22	
			Control module Inocontroller : II (2) D [2 mJ] Matériel associé Inocontroller doit être installé en zone sûre (zone non dangereuse) Associated equipment Inocontroller must be installed in safe zone (non explosive area)	
		(5) Designated standards	EN 50177 : 2009 / A1 : 2013 EN 50050-2 : 2013	EN 60079-0 : 2018 EN 60079-31 : 2014
		(6) Conformity assessment procedures	UK type examination certificate : CML 21UKEX9797X Production Quality Assurance Notification : CML 21UKQAN14372	Approved Body 2503 : Eurofins E&E CML Limited Newport Business Park, New Port Road Ellesmere Port CH65 4LZ UK
Le signe X placé derrière le numéro d'attestation d'examen UK de type indique que cet appareil est soumis à des conditions spéciales d'utilisation: cet appareil est prévu pour une gamme de températures ambiantes de 0°C à 40°C. Lors de l'installation, l'utilisateur devra tenir compte du fait que le clavier du module de commande Inobox n'a subi qu'un choc mécanique faible (groupe II suivant EN 60079-0). Le module de commande Inobox doit être protégé de la lumière. The X sign placed after the UK type examination certificate number indicates that this equipment is intended for an ambient temperature range of 0°C to 40°C. During the installation, the user will take into consideration that the keypad underwent only a shock corresponding to an energy of a low risk (Group II according to EN 60079-0), and must be protected against the high mechanical hazard risk. The Inobox has to be protected from light.				
2016 No. 1091	(5) Designated standards	Inocontroller + Inogun A : EN 61000-6-4 : 2007 /A1 : 2011 EN 61000-6-2 : 2005	Inobox + Inogun M : EN 61326-1 : 2013 EN 50663 : 2017 EN 62479 : 2010	
2016 No. 1101	(5) Designated standards	EN 61010-1 : 2011		
(7) This declaration of conformity is issued under the sole responsibility of the manufacturer.				

Director of the MEYLAN site - Executive Management (EM)

Richard WLODARCZYK

DocuSigned by:

Richard Wlodarczyk

9900D9C0034B4A2...

Established in Meylan, on 27-mars-23 | 18:27 CEST

SAMES

Siège Social / Headquarter: 13, chemin de Malacher - CS70086 - 38243 Meylan Cedex - France - Tél / Phone: +33 (0)4 76 41 60 60
SAS au capital de 12.720.000 euros | RCS Grenoble: 572 051 688 | Code APE: 2829B | TVA intracom: FR36 572051688
info@sames.com - www.sames.com | Société d'EXEL Industries / EXEL Industries company



UK DECLARATION OF CONFORMITY

(1)	<p>Le Fabricant déclare que le matériel désigné ci-après est conforme à la législation d'harmonisation de l'Union applicable suivante/ Der Hersteller erklärt, dass das nachfolgend bezeichnete Material den folgenden anwendbaren Harmonisierungsrechtsvorschriften der Union entspricht / El fabricante declara que el equipo designado a continuación es conforme con la siguiente legislación de armonización de la UE aplicable / Il fabbricante dichiara che l'attrezzatura designata di seguito è conforme alla seguente legislazione di armonizzazione UE applicabile / O Fabricante declara que o equipamento designado abaixo está em conformidade com a seguinte legislação de harmonização aplicável da UE / Producent deklaruje, że urządzenie wskazane poniżej jest zgodne z następującymi obowiązującymi przepisami harmonizacyjnymi UE/ De fabrikant verklaart dat de hieronder beschreven apparatuur in overeenstemming is met de volgende toepasselijke EU-harmonisatiewetgeving/ Výrobce prohlašuje, že níže uvedené zařízení je ve shodě s těmito platnými harmonizačními právními předpisy EU/ Výrobce prohlašuje, že níže uvedené zařízení je ve shodě s těmito platnými harmonizačními právními předpisy EU/ Producenten erklærer, at det nedenfor angivne udstyr er i overensstemmelse med følgende gældende EU-harmoniseringslovgivning/ Valmistaja vakuuttaa, että jäljempänä mainitut laitteet ovat seuraavien sovellettävien EU:n yhdenmukaistamislainsäädännön mukaisia./ Tootja kinnitab, et allpool nimetatud seadmed vastavad järgmistele kohaldatavatele ELi ühtlustamise õigusaktidele./ Ražotājs apliecina, ka turpmāk norādītās iekārtas atbilst šādiem piemērojamiem ES saskaņošanas tiesību aktiem./ Gamintojas pareiškia, kad toliau nurodyta įranga atitinka šiuos taikytinus ES derinamuosius teisės aktus/ Производителят декларира, че посоченото по-долу оборудване е в съответствие със следното приложимо законодателство на ЕС за хармонизация/ A gyártó kijelenti, hogy az alább megjelölt berendezés megfelel a következő alkalmazandó uniós harmonizációs jogszabályoknak / Producătorul declară că echipamentul desemnat mai jos este în conformitate cu următoarea legislație de armonizare a UE aplicabilă/ Ο κατασκευαστής δηλώνει ότι ο εξοπλισμός που αναφέρεται κατωτέρω συμμορφώνεται με την ακόλουθη ισχύουσα νομοθεσία ενωμοσύνης της ΕΕ/ Προizvođač ovime izjavljuje da je oprema u skladu sa zakonskim zahtjevima Ujedinjene Kraljevine./ Výrobca vyhlasuje, že nižšie uvedené zariadenie je v súlade s týmito platnými harmonizačnými právnymi predpismi EÚ/ Произвојалец изјављује, да је сподјат наведена опрема складна з насљедној вељавно усклајевално законоданој ЕУ/ Производител заявляет, что указанное ниже оборудование соответствует следующим применимым законодательным актам ЕС по гармонизации/ 製造者は、以下に指定された装置が、適用される以下のEU調和法に適合していることを宣言する。/ 製造商声明, 下面指定的设备符合以下适用的欧盟协调立法。</p>
(2)	<p>Type d'équipement/ Art der Ausrüstung/ Tipo de equipo/ Tipo di attrezzatura/ Tipo de equipamento/ Rodzaj sprzętu/ Type uitrusting/ Typ zařízení/ Typ av anordning/ Type af anordning/ Laitteen tyyppi/ Seadme tüüp/ Iekārtas tips/ Įrangos tipas/ Вид оборудване/ A berendezés típusa/ Tipul de echipament/ Τύπος εξοπλισμού/ Vrsta opreme/ Typ zariadenia/ Vrsta naprave/ Тип оборудования/ 機器の種類/ 设备类型</p>
(3)	<p>Directives applicables/Anwendbare Richtlinien/Directivas aplicables/Direttive applicabili/Diretivas aplicáveis/Obowiązujące dyrektywy/Toepasselijke richtlijnen/Platné smernice/Tillämpliga direktiv/Gældende direktiver/Sovellettavat direktiivit/Kohaldatavad direktiivid/Piemērojams direktīvas/Taikomos direktyvos/Приложими директиви/Alkalmazandó irányelvek/Directive aplicabile/Ισχύουσες οδηγίες/Primjenjive smjernice/Uplatnitelne smernice/Veljavne directive/Применимые директивы/適用される指令/适用的指令</p>
(4)	<p>Marquage/Markierung/Marcação/Marcatura/Marcação/Znakowanie/Marketing/Označení/Märkning/Mærkning/Merkintä/Märkistus/Marķējums/Ženklinimas/Маркировка/Jelölés/Marcare/Ἱζηλωση/Obilježava/Označovanie /Označevanje/Маркировка/マーキング/标识</p>
(5)	<p>Normes désignées/Bezeichnete Normen /Normas designadas /Norme designate /Normas designadas /Normy wyznaczone / Aangewezen normen/Určené normy /Uitgekade standarder /Udpegede standarder /Nimetyl standardit /Māāratud standardiā /Izraudzītie standarti /Paskirtieji standarti /Определени стандарти /Kijelölt szabványok /Standarde desemnate /Καθορισμένα πρότυπα /Određeni standardi /Určené normy / Določeni standardi /Назначенные стандарты /指定された規格 /指定的标准</p>
(6)	<p>Procédure d'évaluation de la conformité/Verfahren der Konformitätsbewertung/Procedimiento de evaluación de la conformidad/Procedura di valutazione della conformità/Procedimento de avaliação da conformidade/Procedura oceny zgodności/Conformiteitsbeoordelingsprocedure/Postup posuzování shody / Förfarande för bedömning av överensstämmelse/Procedure for överensstemmelsesvurdering /Vaatimustenmukaisuuden arviointimenettely /Vastavushindamismenetlus/Atbilstības novērtēšanas procedūra /Atitikties vertinimo procedūra /Процедура за оценка на съответствието /Megfelelőségértékelési eljárás / Procedura de evaluare a conformității/Διαδικασία αξιολόγησης της συμμόρφωσης /Postupak ocjene usklađenosti /Postup posuzovania zhody /Postopek ugotavljanja skladnosti /Процедура оценки соответствия /適合性評価手順 /適合性評估程序</p>
(7)	<p>Cette déclaration de conformité est délivrée sous la seule responsabilité du fabricant. / Diese Konformitätserklärung wird unter der alleinigen Verantwortung des Herstellers ausgestellt./ Esta declaración de conformidad se emite bajo la única responsabilidad del fabricante./ Questa dichiarazione di conformità è rilasciata sotto la sola responsabilità del produttore./ Esta declaração de conformidade é emitida sob a exclusiva responsabilidade do fabricante./ Niniejsza deklaracja zgodności została wydana na wyłączonej odpowiedzialności producenta./ Deze verklaring van overeenstemming wordt afgegeven onder de uitsluitende verantwoordelijkheid van de fabrikant./ Toto prohlášení o shodě je vydáno na výhradní odpovědnost výrobce./ Denna försäkringen om överensstämmelse utfärdas på tillverkarens eget ansvar. / Denne overensstemmelseserklæring er udstedt på producentens eget ansvar./ Tämä vaatimustenmukaisuusvakuutus annetaan valmistajan yksinomisella vastuulla./ Käesolev vastavusdeklaratsioon on välja antud tootja ainuvastutusel./ Šī atbilstības deklarācija ir izdota uz ražotāja atbildību./ Už šīs atitikties deklarācijai atsako tik gamintojas./ Настоящата декларация за съответствие се издава на пълната отговорност на производителя./ Ezt a megfelelőségi nyilatkozatot a gyártó kizárólagos felelősége mellett adjuk ki./ Prezenta declarație de conformitate este emisă pe răspunderea exclusivă a producătorului./ Η παρούσα δήλωση συμμόρφωσης εκδίδεται με αποκλειστική ευθύνη του κατασκευαστή./ Ova izjava o skladnosti izdaje se isključivo pod odgovornošću proizvođača./ Tohto vyhlásenie o zhode sa vydáva na výhradnú zodpovednosť výrobcu./ Za to izjavo o skladnosti je odgovoren izključno proizvajalec./ Din iddikjarazzjoni ta' konformità għandha tinhaqgħ taht ir-responsabbiltà unika tal-manifattur./ Данная декларация соответствия выдана под исключительную ответственность производителя./ この適合宣言は、製造者の単独責任のもとで発行されています。/本符合性声明由制造商全权负责发布。</p>

SAMES

Siège Social / Headquarter: 13, chemin de Malacher - CS70086 - 38243 Meylan Cedex - France - Tél / Phone: +33 (0)4 76 41 60 60
 SAS au capital de 12.720.000 euros | RCS Grenoble: 572 051 688 | Code APE: 2829B | TVA intracom: FR36 572051688
info@sames.com - www.sames.com | Société d'EXEL Industries / EXEL Industries company



Sames

13, Chemin de Malacher
38240 Meylan - France
☎ 33 (0)4 76 41 60 60

www.sames.com